



SHENZHEN MISSILER TECHNOLOGY CO., LTD.

Add: B205, Smart Valley Innovation Plaza, No.542 Minzhi Rd.,
Longhua District, Shenzhen, China

Contact: Jeny Yan

Mobile/WeChat: 0086 136 1300 6838

Phone: 0755-2376 1419

Whats App: 0086 136 1300 6838

Skye: mex.jeny

E-mail: jeny@missiler.com

https: //www.missiler.com

https: //www.globalsources.com/missiler.co



SMART LIGHTING SOLUTIONS

2022-2023

Shenzhen Missiler Technology Co., LTD.

Shenzhen Missiler Technology Co., LTD., founded in 2012, is located in the Guangdong-Hong Kong-Macao Greater Bay Area, with convenient transportation and access to the world. The factory is located in the world famous lighting city - Zhongshan Guzhen of China.

The company focuses on the research and development, production and sales of smart lighting products. We mainly produce and customize for smart LED recessed lights like down lights and spotlights, smart LED magnetic track lights, smart LED linear lights and smart LED strip lights, etc. The founding team is a group of veterans who have been deeply engaged in smart lighting products and Internet of Things industry solutions for years. They always keep the frontier pace of science and technology, constantly iterating and advancing with the Times.

Our LED lighting products are featured with high luminous, high color rendering index, long life, low energy consumption, flexible light dimming and color changing by choosing the superior LED chips and fine die-casting aluminum lamp body combined with our strong convection design and smart technology application. We implement a strict management standard for the procedures of lighting effect control, light source configuration, lamp body mold opening, LED lights production, products testing and packaging, to guarantee a safe production progress and order fulfillment. We provide one-stop OEM, ODM professional manufacturing service.

The company has strong technical R & D and production strength, has a group of experienced technical and management personnel, and is equipped with advanced production equipment and instruments. Several large-scale production equipment passed the iso9001-2015 quality management system certification in 2022. It has obvious advantages in domestic counterparts. The products sell well at home and abroad and are widely praised and welcomed.

The company's smart LED lighting products line covers household, office, hotel, commercial exhibition hall and indoor public lighting and other application scenarios. And we also offer our customers with smart solutions like smart lighting, smart home, smart office, smart hotel, smart agriculture and so on.

We will adhere to the concept of "lighting, health, comfort, smart" and the pursuit of a better light environment, to provide professional smart lighting products and smart solutions.

Service purpose

Concentration, craftsmanship, efficiency, professionalism.

Corporate culture

Pursuit of value, lead the frontier, integrate into the ecology and win-win cooperation

Enterprise vision

We are committed to the fields of smart lighting and IOT interworking technology to create a "lighting, healthy, comfortable and smart" light environment.

ENTERPRISE QUALIFICATION



COOPERATIVE BRAND



Recessed lights

P01-48



P01-12 P13-22 P23-26 P27-30 P31-32 P33-34



P35-36 P37-38 P39-40 P41-44 P45-46 P47-48

Magnetic track lights

P49-56



P53 P53 P54 P54 P55 P56

Strip lights

P57-66



P59-60 P61-62 P63-64 P65-66

Linear lights

P67-70

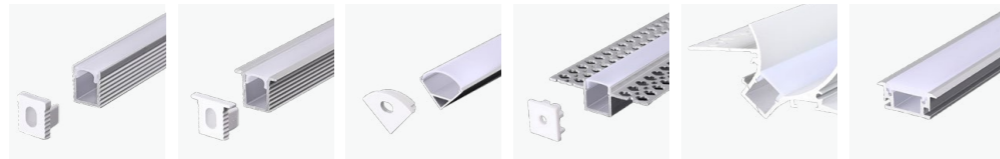

P67 P67-68 P68 P68 P68 P68

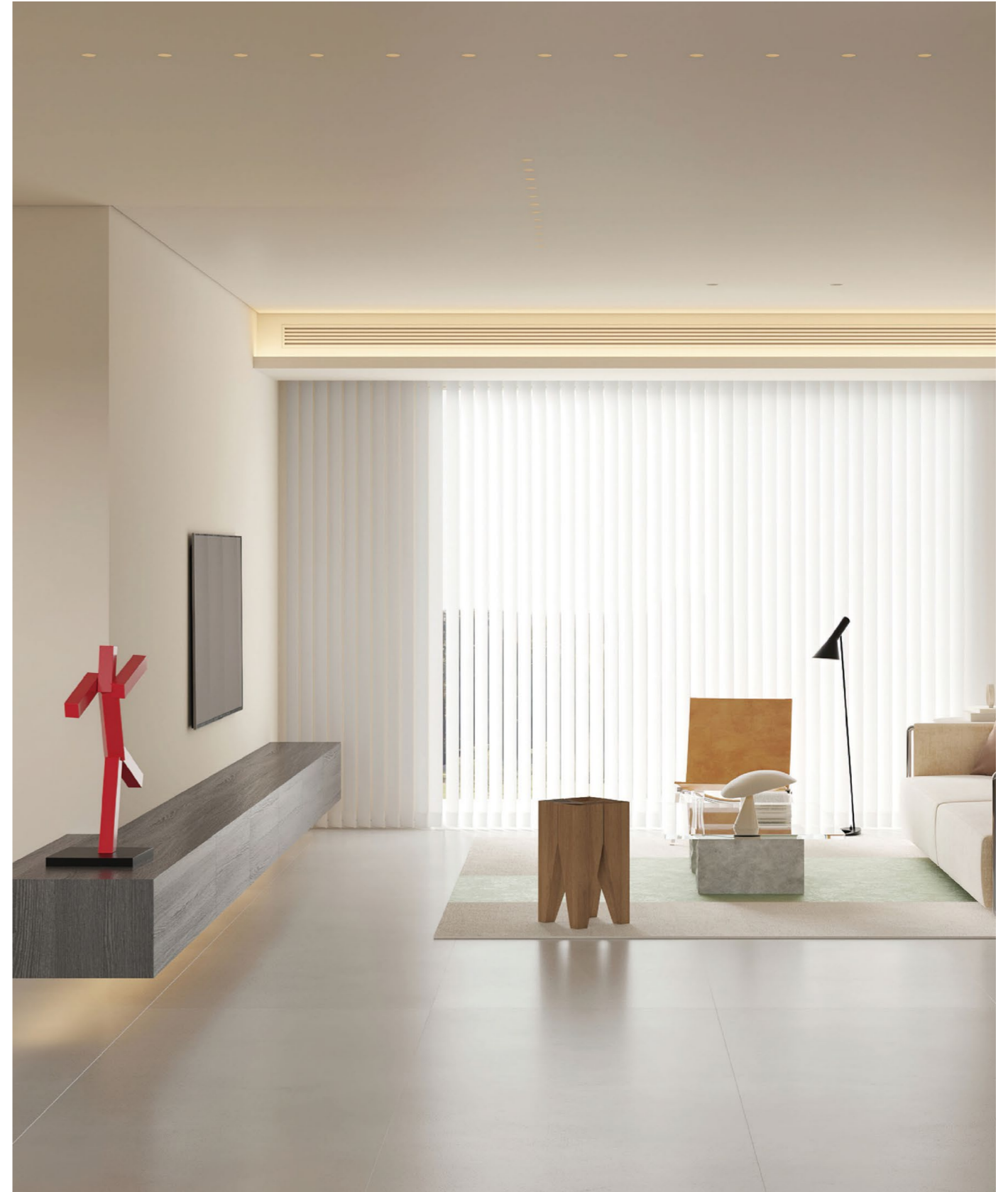



WISH PRO

WALL WASHING SPOTLIGHT SERIES

WISH PRO WALL WASHING SPOTLIGHT, BASED ON THE ORIGINAL WISH SERIES UPGRADED ENHANCED VERSION, HAS NEW KEY ITERATION INDICATORS AS BELOW:

- Design style: thick texture and simple appearance
- Optical lens: customized PMMA lens, wall washer spot more clear and natural
- Optical effect: clean wall hill effect, simultaneously compatible with two-color, five-color mixed color effect.

DEEP ANTI-GLARE LED WALL WASHER SPOTLIGHT

1. Details processing of lamps:

-The enhanced appearance of the overall ornamental and perfect, loaded mounting buckle, and the narrow edge design for the reflective cup and face ring, highlighting the overall line to be simple and smooth.

2. Product structure design:

-This series of products are optimized for light control and heat dissipation system, using modular combination and multi-component collocation. The surface ring has round, square, round frameless embedded, square frameless styles, flexible to match a variety of ceiling modeling. By matching the direct light and adjust the swing angle of light accessories, it meets the multi-level lighting design principle and environment three-dimensional sensory effect; At the same time add anti-glare black honeycomb mesh, UV mirror, optical stretch mirror, soft mirror, cubic floodlight mirror surface and more different optical filter mirror for different Application scenario requirements.

3. A variety of optical equipment:

- Polarizing wall washing, keep the light from the luminaires irradiation distance and light uniformity, highlight the overall wall,
- Avoid shadows and dark areas, adjustable swing cast light, reflect the accuracy of the angle of the cast light and the texture of the object being illuminated, restore the brightness of texture and color;
- Direct luminous lighting, deepening anti-glare treatment (UGR value), precise control of the light path, to achieve "See the light, not seeing the lamp" effect;
- Angle of projection: Angle 15°, Angle 24°, Angle 36°, and Angle 55°, which can be selected based on the irradiation area requirements to achieve the application effect of key lighting and flood lighting.
- The Radiator adopts circular vane ventilation design, heat dissipation area using GB ADC12 aluminum with fast heat transmission, fast chip heat dissipation, reduce the light failure of the luminescent chip, guarantee a longer service life;
- Various specifications are optional, optional power wattage from 5W to 80W (according to the chip parameters), to meet the requirements of different lighting applications.



PROFESSIONAL LIGHT HEALTH, LIGHT QUALITY LED LIGHTING TECHNOLOGY

<p>Aestheticism</p> <p>-As many as dozens of subdivided standard light color, the pursuit of the ultimate light color, so that the space and the subject can be restored their own exclusive light color, present the best display effect, perfect health and comfort.</p>	<p>Stability</p> <p>-Using "multiple thermal conductivity" patent technology, and the latest phosphor deposition process, the product internal achieves the best thermal balance and low resistance, the substrate for a long time at 105°C high temperature, product colorless temperature drift, and has a stable lumen maintenance rate.</p>
<p>Consistency</p> <p>-The COB light source is at 85°C constant temperature, and the 2-step MacAdem(McAdam) elliptic standard is used to divide the light-color BIN region, so as to achieve the light-color consistency of the products in the BIN region and the consistency of the light color in different periods in the same BIN region.</p>	<p>High Density</p> <p>-To achieve unparalleled lumen density output, small Angle, high illumination, and better control of light distribution, adopt a smaller, more delicate structure of lamps, showing "see light but not seeing lamp".</p>
<p>Reliability</p> <p>-Adopt high precision overcoating structure and industry-leading eutectic process, without fear of external extrusion, avoid the risk of damage to the light source during production and installation. At 180°C high temperature substrate, the product can be normally lit, and has high physical strength and high temperature bearing capacity, so that COB light source is no longer fragile.</p>	<p>High Dolor Equalization</p> <p>-RGBCW < 3SCDM</p>

SMART LED DRIVER(ZIGBEE/BLE)

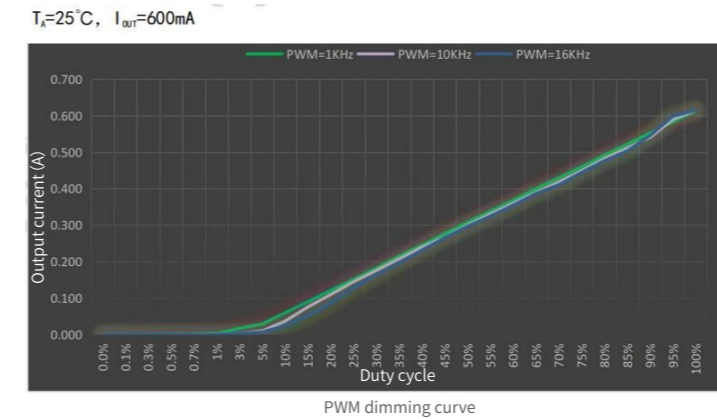

LED DRIVER TECHNICAL FEATURES:

- 65536 high brightness dimming, dimming depth up to 0.1%;
- High precision constant current, low ripple output without strobe, prolong lamp bead life; Soft start fade on fade off function, protect
- Holding; visual more comfortable;
- Full voltage design, universal; Use 650V high voltage MOS, support wider working voltage range, can prevent surge voltage impact damage drive, prolong service life;
- With overheating protection function;
- With output short circuit protection function;
- Multi-mode control chips supporting QRM, DCM and PFM are selected to maintain high working efficiency and response speed.
- The drive power provides multi-position pull code switching, can match a variety of functional requirements, more simple and convenient;
- Built-in antenna control module, wireless signal matching degree is more stable, maintain long-distance transmission and sensitive control experience;
- Support Amazon Alexa, Google Assistant, Apple Homekit, Samsung Smart Things, Yandex Station, Tmall genie etc and other mainstream intelligent voice control.

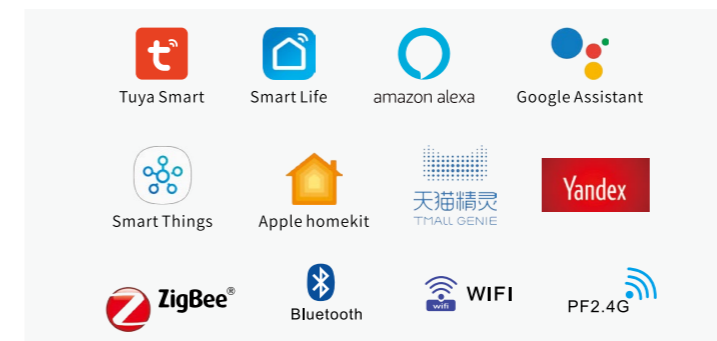

WISH PRO WALL WASHER SPOTLIGHT

- Cast light clean, without light spot stratification;
- The two-color rendering index is greater than 90;
- Monochrome full spectrum Ra>98 to ensure visual comfort;
- Five-color mixed-color W/CW + RGB, RGB combined with two-color white lighting;
- Intelligent and personalized combination, to achieve full color, multi-scene and diversified lighting, making a new vision smart lighting!

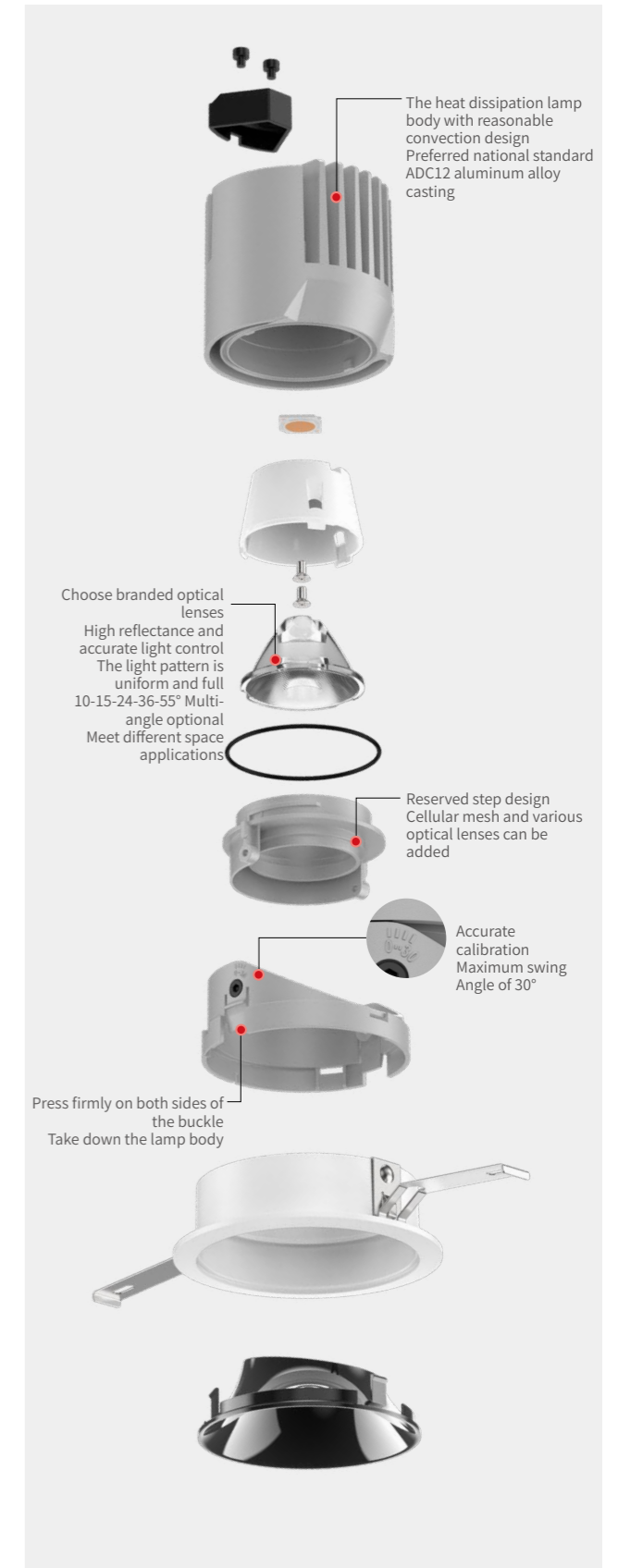

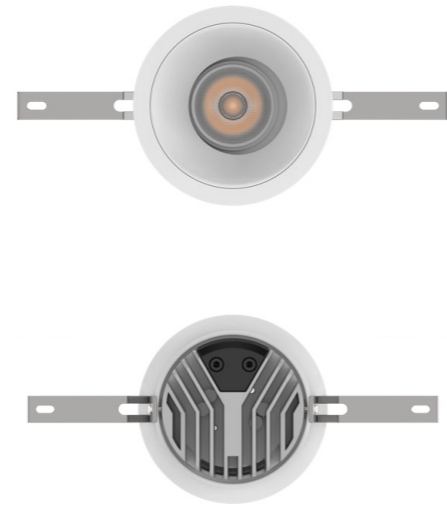
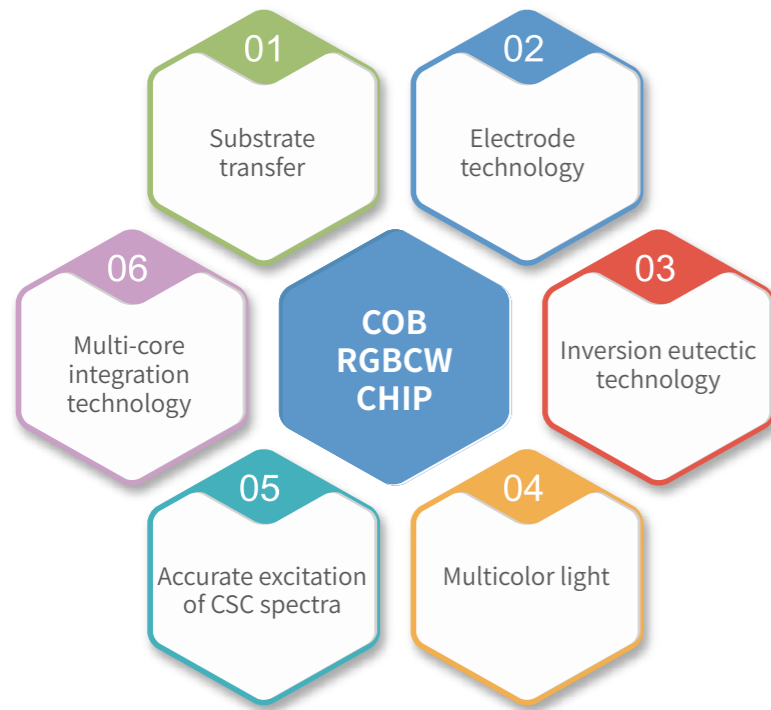

Application : Luxury houses, hotels, clubs, exhibition halls, office buildings, office areas, etc

LIGHT COLOR AND PSYCHOLOGICAL INFLUENCE

Just Red	Red can increase the feeling of warmth, help to improve one's mental outlook, and can improve blood circulation, breathing rate and mood.
Orange Red	Tangerine (orange) make the person mood happy, can stimulate the mood effectively.
Cosmic Latte	There is poetic light, time rhythm guidance, leisure time needs light color
Chartreuse Yellow	It's the kind of light that makes you want to drink, and it's the color of many different kinds of concoctions. A study in the Journal of Physical Therapy Science found that exposure to yellow light made people more inclined to engage in vigorous activity compared to blue and red light.
Office Green	Studies have shown that children with autism prefer cold tone, such as green tone and blue tone. Green tea has a good effect on relieving the depression or relieving the depression of the old age, also known as green tea therapy.
Aqua Menthe	Sunny light, or can give you a good mood. This is the color that many patients prefer. pressure has a very good effect, also known as non-drug green therapy.
Just Blue	Sunny light, or can give you a good mood. This is the color that many patients prefer. help settle down the children with autism and neurasthenia.
Moonlight	Outdoor tents may need moonlight.
Blush pink	Studies have shown that a certain shade of pink helps people fall asleep more easily than a warmer shade of light around 2500K.
Proton Purple	Purple brings serenity, calmness and fantasy, and pregnant women can find solace in the purple environment to help them recover. People with depression prefer purple.
2700K Light	Daily lighting (Ra>90), winter or bedroom lighting.
4000K Light	Daily lighting (Ra>90), study, tea room use it.
6000K Light	Daily lighting (Ra>90) for hot summer days.

Influence of light on people

Thanks to the development of technology, we are able to decide on brightness, colour and other parameters of light which influence our mood, ability to focus and our overall well-being. As recommended by medical communities, the type of lighting should be similar to natural light as far as possible, in order to match it to a person's sleep-wake rhythm. It allows for maximum support of our concentration and calms us down before going to sleep - to rest effectively.

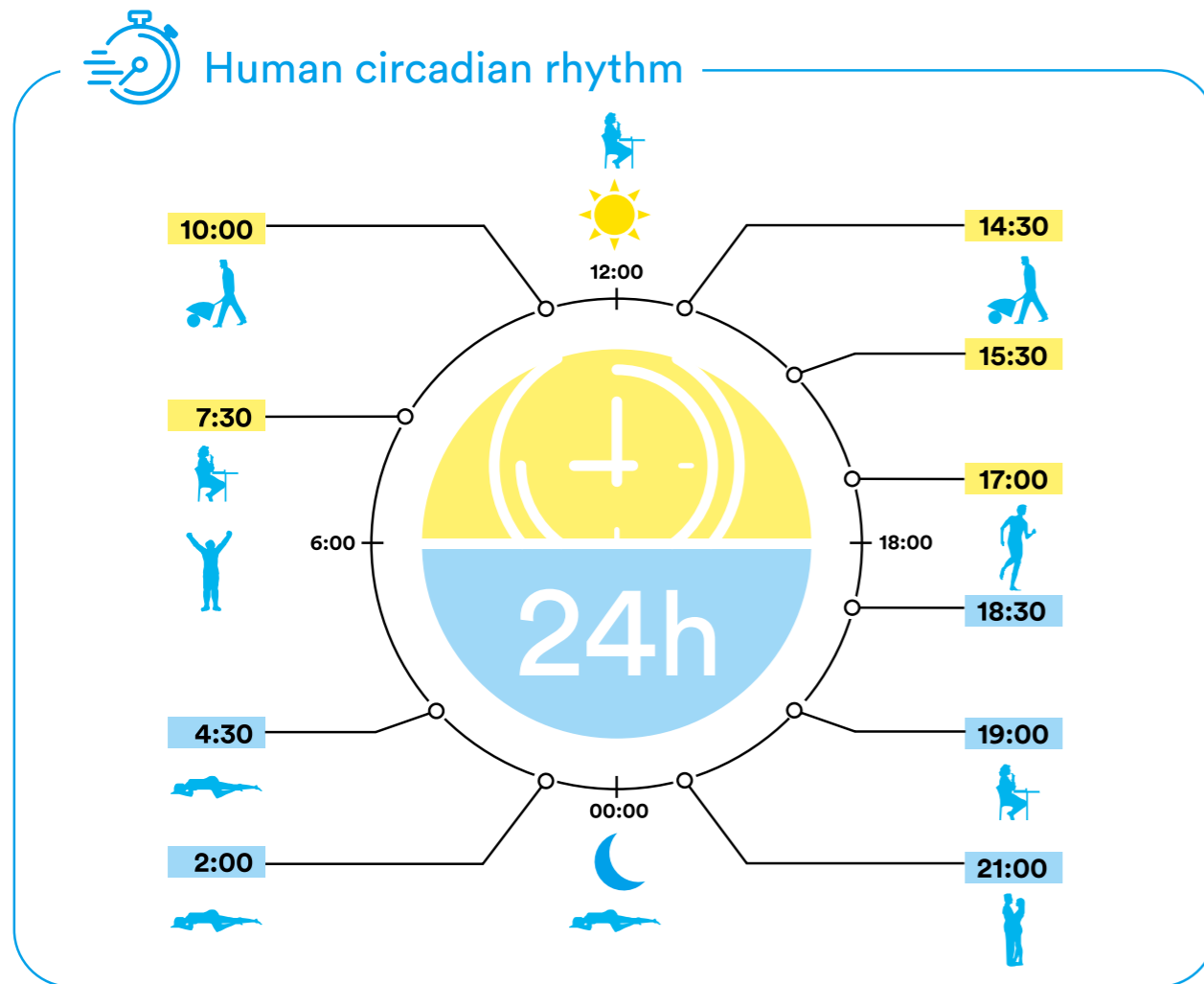

INTELLIGENT • FULL COLOR

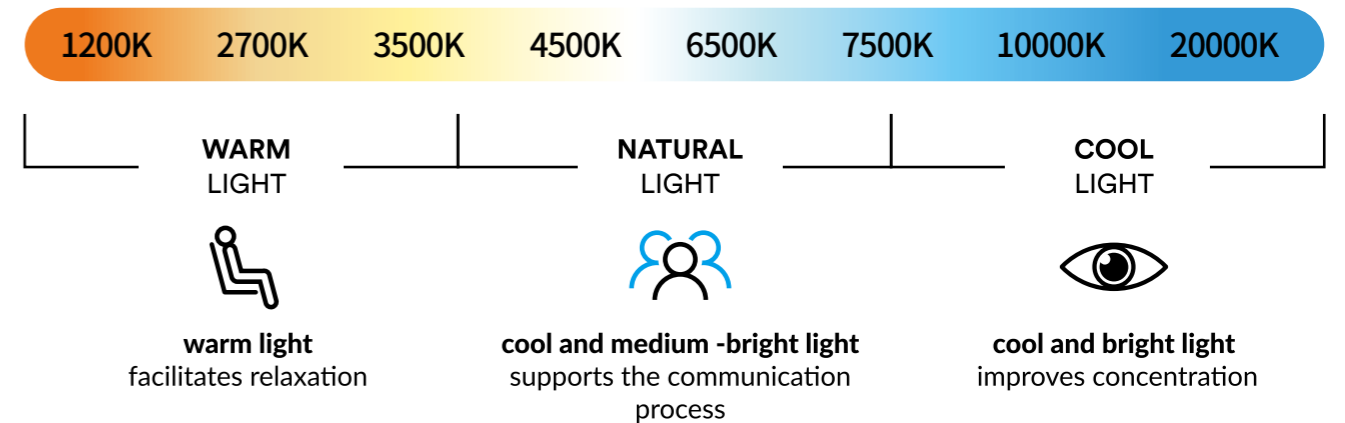

Natural light

It has been proven that following the changes of natural light during the day brings immense physiological and psychological benefits. This aspect seems to be even more important as sleep and concentration disorders, stress and symptoms of modern-age diseases are becoming increasingly common.

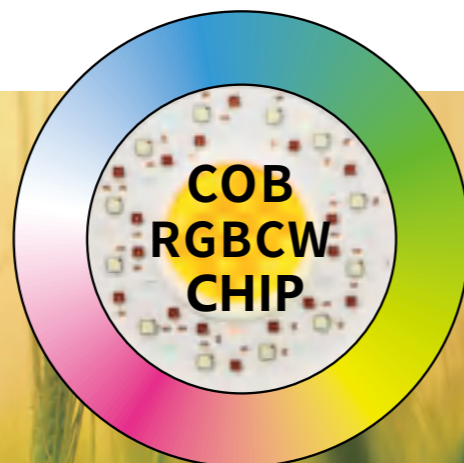

Tunable RGBCW full color is applicable in all places where people have activities.

- improve efficiency when working in the office.
- ensure that your mood is good and improve recovery of patients in hospitals.
- positively influence concentration and learning efficiency in schools.
- create an appropriate environment for discussions and meeting in conference halls.
- maintain high level of productivity, 24 hours a day in production line.
- emphasize products and their colour in shops, improve the level of artistic experience in museums.

Products Parameter

○ White
● Black

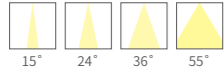

Model No.	ZX-RYXQ-05	ZX-RYXQ-10	ZX-RYXQ-10
Power	5W	10W	10W
Voltage	AC220-240V	AC220-240V	AC220-240V
CCT	3000K/3500K/4000K/6000K	3000K/3500K/4000K/6000K	3000K/3500K/4000K/6000K
CRI	Ra≥90	Ra≥90	Ra≥90
UGR	<13	<13	<13
Flux	350Lm	750Lm	750Lm
Size	Ø62*H75mm	Ø85*H89mm	Ø85*H89mm
Cut-size	Ø55mm	Ø75mm	Ø75mm
IP Rate	IP 20	IP 20	IP 20
Chip	CREE, bridgelux, OSRAM	CREE, bridgelux, OSRAM	CREE, bridgelux, OSRAM

Product size unit (mm)

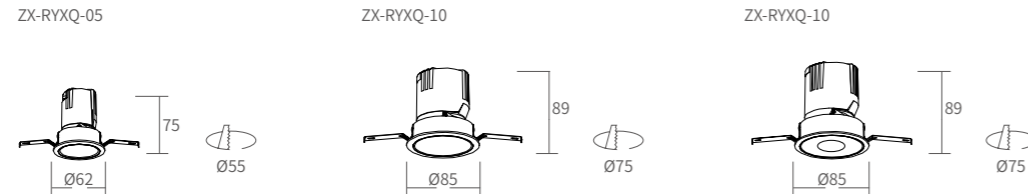

Optional Reflective Cup



Smart function optional

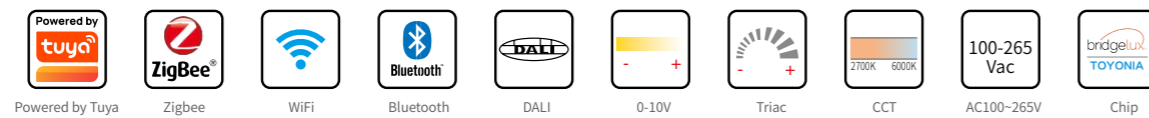

Application : Luxury houses, hotels, clubs, exhibition halls, office buildings, office areas, etc

Products Parameter

○ White
● Black



Model No.	ZX-RYXQ-10 (Polarized)	ZX-RYXQ-15	ZX-RYXQ-30
Power	10W	15W	24W
Voltage	AC220-240V	AC220-240V	AC220-240V
CCT	3000K/3500K/4000K/6000K	3000K/3500K/4000K/6000K	3000K/3500K/4000K/6000K
CRI	Ra≥90	Ra≥90	Ra≥90
UGR	<13	<13	<13
Flux	750Lm	1100Lm	1700Lm
Size	Ø85*H89mm	Ø104*H115mm	L158*W85*H90mm
Cut-size	Ø75mm	Ø95mm	L148*W75mm
IP Rate	IP 20	IP 20	IP 20
Chip	CREE, bridgelux, OSRAM	CREE, bridgelux, OSRAM	CREE, bridgelux, OSRAM

Product size unit (mm)

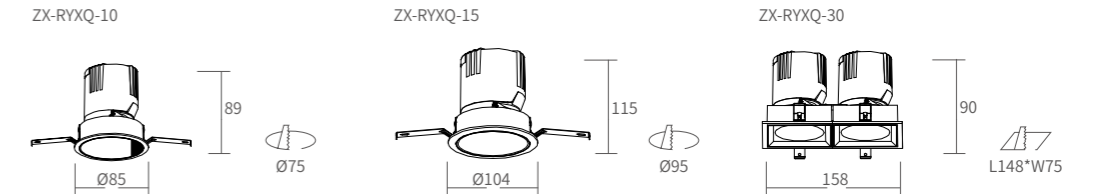

Optional Reflective Cup



Smart function optional

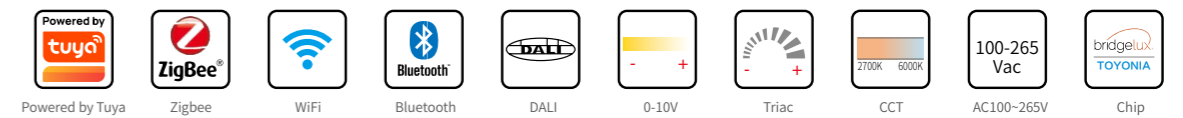

Application : Luxury houses, hotels, clubs, exhibition halls, office buildings, office areas, etc

Products Parameter

○ White
● Black

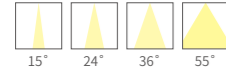

ZX-RYXQ-05WB



ZX-RYXQ-10WB



ZX-RYXQ-10WB (elliptical hole/round hole)

Model No.	ZX-RYXQ-05WB	ZX-RYXQ-10WB	ZX-RYXQ-10WB
Power	5W	10W	10W
Voltage	AC220-240V	AC220-240V	AC220-240V
CCT	3000K/3500K/4000K/6000K	3000K/3500K/4000K/6000K	3000K/3500K/4000K/6000K
CRI	Ra≥90	Ra≥90	Ra≥90
UGR	<13	<13	<13
Flux	350Lm	750Lm	850Lm
Size	Ø77*H75mm	Ø100*H89mm	Ø100*H89mm
Cut-size	Ø55mm	Ø75mm	Ø75mm
IP Rate	IP 20	IP 20	IP 20
Chip			

Product size unit (mm)

ZX-RYXQ-05WB

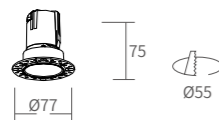

ZX-RYXQ-10WB

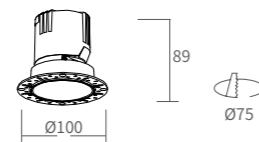

ZX-RYXQ-10WB

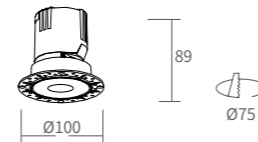

Optional Reflective Cup



Smart function optional

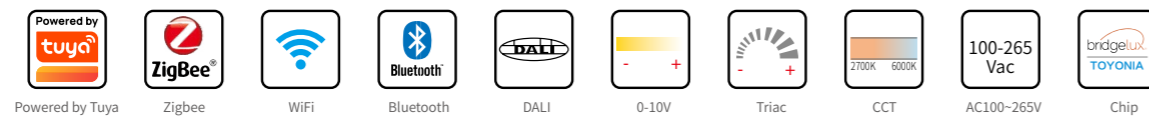

Application : Luxury houses, hotels, clubs, exhibition halls, office buildings, office areas, etc

Products Parameter

○ White
● Black



ZX-RYXQ-10WB (Polarized)



ZX-RYXQ-15WB

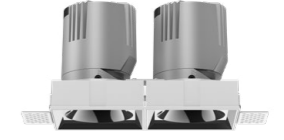

ZX-RYXQ-30WB

Model No.	ZX-RYXQ-10WB	ZX-RYXQ-15WB	ZX-RYXQ-30WB
Power	10W	15W	24W
Voltage	AC220-240V	AC220-240V	AC220-240V
CCT	3000K/3500K/4000K/6000K	3000K/3500K/4000K/6000K	3000K/3500K/4000K/6000K
CRI	Ra≥90	Ra≥90	Ra≥90
UGR	<13	<13	<13
Flux	750Lm	1100Lm	1700Lm
Size	Ø100*H89mm	Ø120*H115mm	L144*W72*H90mm
Cut-size	Ø75mm	Ø95mm	L145*W73mm
IP Rate	IP 20	IP 20	IP 20
Chip			

Product size unit (mm)

ZX-RYXQ-10WB

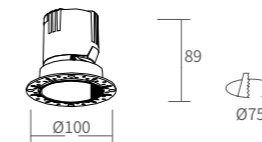

ZX-RYXQ-15WB

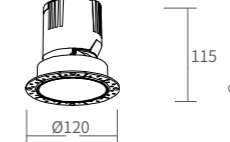

ZX-RYXQ-30WB

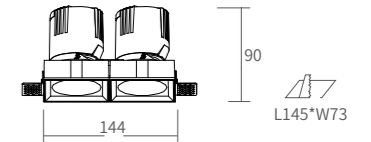

Optional Reflective Cup

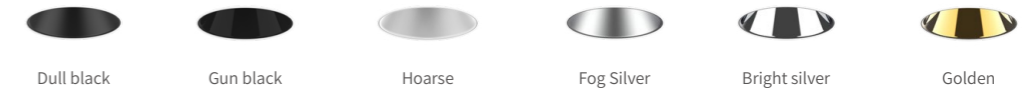

Smart function optional

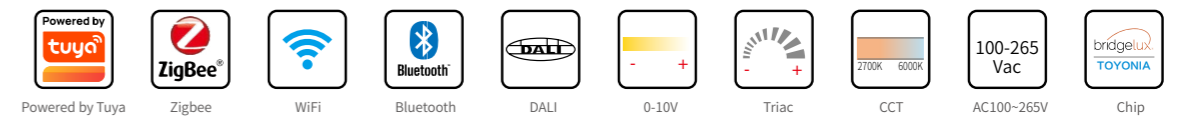

Application : Luxury houses, hotels, clubs, exhibition halls, office buildings, office areas, etc

TANHOO

DEEP ANTI DAZZLE WALL WASHER SPOTLIGHT SERIES

SUPPORT MULTIPLE INTELLIGENT LINKING METHODS







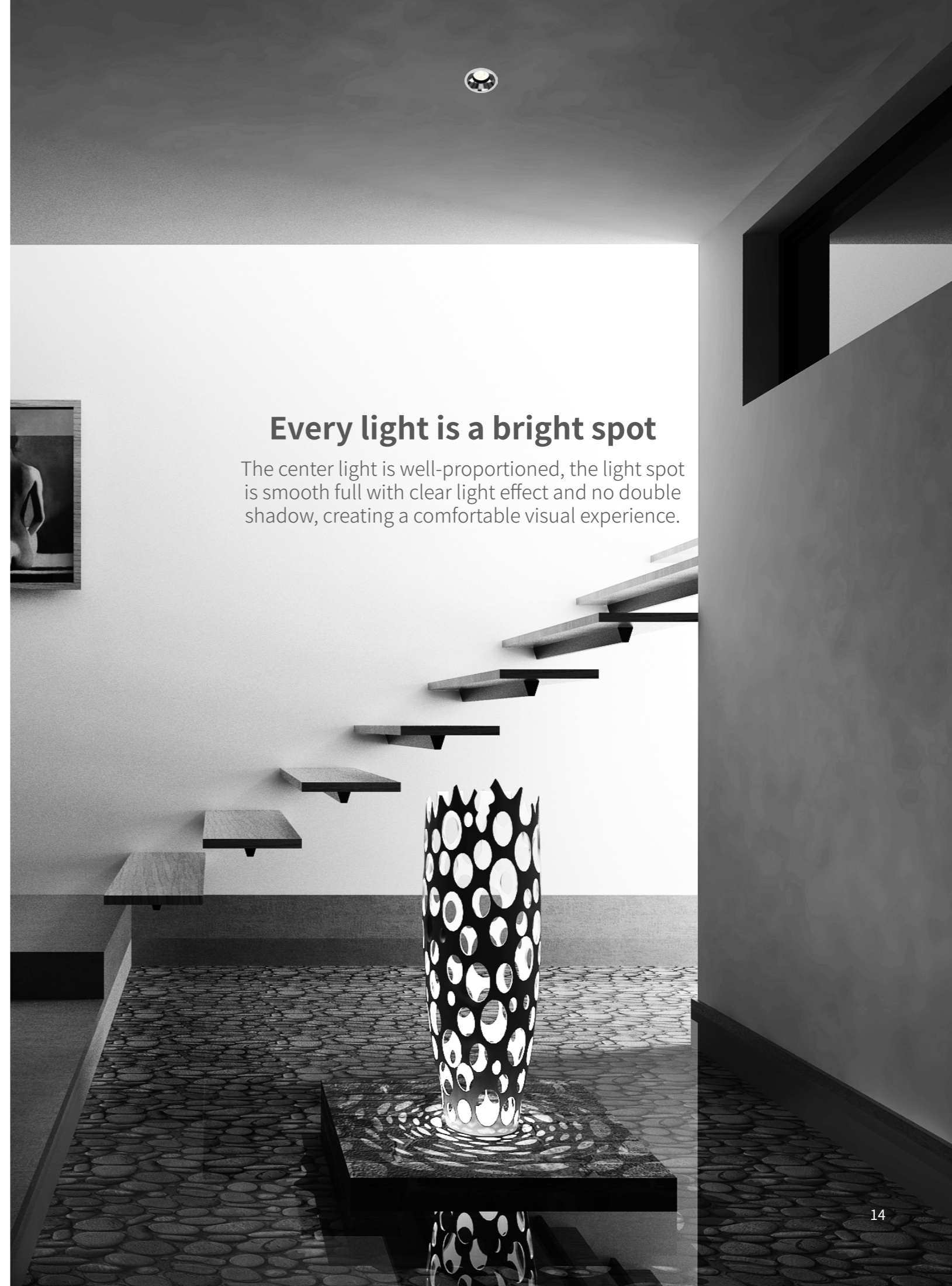







Every light is a bright spot

The center light is well-proportioned, the light spot is smooth full with clear light effect and no double shadow, creating a comfortable visual experience.



Product features

-  High Efficiency
-  CE Certification
-  UGR <13
-  HIGH CRI Ra>95
-  Smart Dimmable
-  IP20 Protection Level
-  Anti-glare cut off angle >30°
-  Different sizes
-  Eye protection without stroboscopic
-  High Quality LED Chip
-  Visual comfort
-  Customizable

Application : Luxury houses, hotels, clubs, exhibition halls, office buildings, office areas, etc

SMALL OPENING, HIGH POWER, DELICATE



EVERY DETAIL IS THE CHOICE OF QUALITY



fashion appearance with quality texture

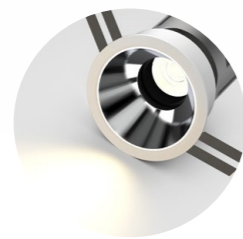

Ra>95 near natural light



Efficient heat dissipation prolong the service life

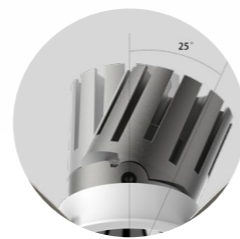

Irradiation Angle 25° adjustable



A
Radiator

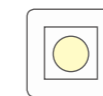

B
Light source



C
Bracket



D
Lens



E
Retaining ring



F
Rotating ring



G
Face ring



H
Reflector

1. HEALTH: NO BLUE LIGHT HARM, NO STROBOSCOPIC DAMAGE

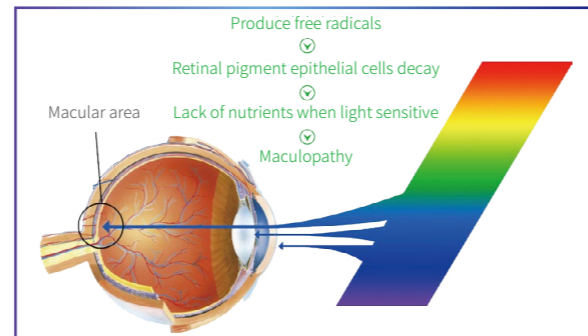
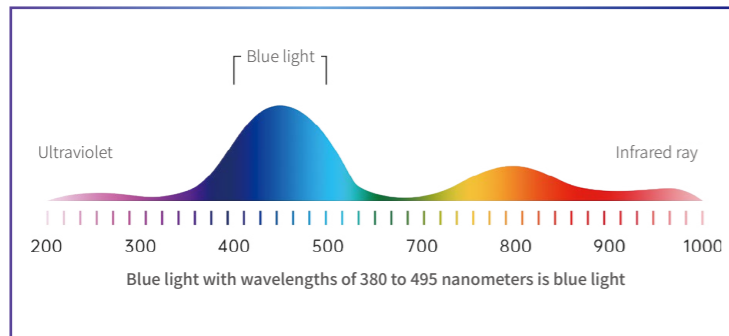

About blue light hazards - Visual nerve damage

Blue light is ubiquitous in our lives. In addition to LED lights, blue light is found in LCD screens of digital products such as mobile phones and tablets. Long-term, heavy exposure to blue light, such as not having a phone or tablet in your hand all day, can increase the risk of cataracts and blindness due to macular degeneration.

The extent to which blue light is harmful to the eyes varies with age. In older people, the crystals turn yellow with age; And the child is sensitive to intense blue light, can cause vision to decline, even produce eye disease. It is worth noting that we generally do not look directly at LED lights in real life, but we will look directly at mobile phones and computer screens for a long time. Only by forming good eye habits we can effectively reduce the damage caused by blue light.



Anti-glare design

The normal range of attention of the human eye is 30° to 60° from the top to the bottom of the horizontal gaze. Dazzling light appears within the intercept Angle of >30°, so glare is well controlled.

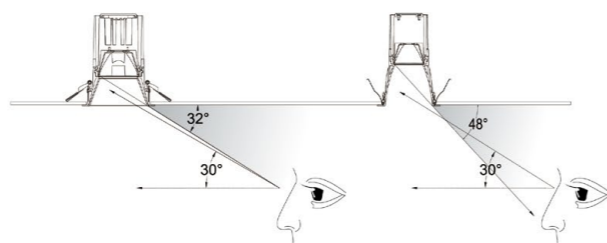

UGR<13

Give your eyes a comfortable light environment

Triple anti-glare structure design, optimize the light borrowing Angle, the product anti-glare index reaches UGR<13, long time use will not cause eye discomfort.

UGR division of lighting products

intolerable	25-28
uncomfortable	22-25
It doesn't feel harsh	19-22
Tolerable degree of glare	16-19
You don't feel the glare	13-16
Acceptable level of glare	10-13
Professional-grade products (suitable for hospital operating room)	<10

※ The measured BGR of Tanhoo series is less than 13, which is up to the standard of professional optical products.

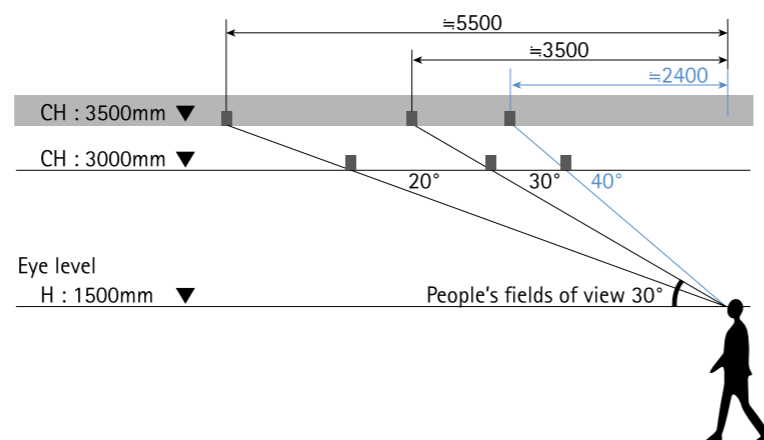

Application : Luxury houses, hotels, clubs, exhibition halls, office buildings, office areas, etc

2. HUMAN FACTOR LIGHTING: DEFINITIONS

The broad idea of human factor lighting is:

The application of lighting technology, so that lighting, climate and space perfect integration, so that people in the physical, emotional, health and other aspects of help, to meet the human needs of lighting in a specific application environment.

To realize human factor lighting, there are the following key factors:

The application of lighting technology, so that lighting, climate and space perfect integration, so that people in the physical, emotional, health and other aspects of help, to meet the human needs of lighting in a specific application environment.

- Provide high quality light sources to increase visual appeal
 - Full spectrum can bring higher color reduction index in the visual range, especially CR and R1-R99
- Personalized requirements and controls
 - Support adjustment according to personal preference: lighting intensity, color, atmosphere
 - Circadian rhythms are adjustable to mimic the level of sunlight throughout the day
- Ensure that the transmitted light is close to natural light
 - The spectrum has to be able to mimic as natural a spectrum as possible, because people have been living under natural light for millions of years, especially sunlight during the day and moonlight at night, firelight
 - Avoid disruption of circadian rhythms due to spectral deviations

Chromogenic index (Ra) ≥95

Full spectrum lighting, museum-grade lighting effect

Average chromogenic evaluation index:

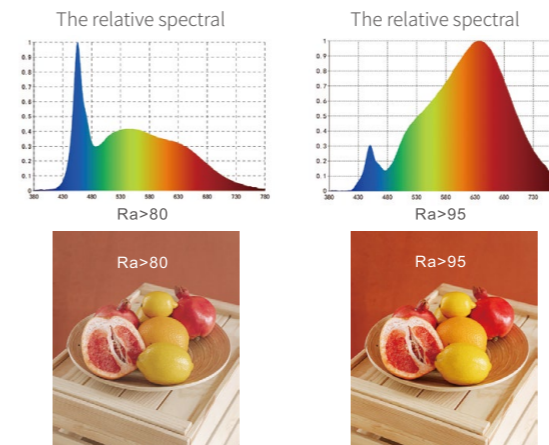

Color Rendering Index refers to the difference between the illuminate of light feeling is different, now is the best color rendering index 100 (natural) is more close to 95, for both color reduction degree is also need to distinguish, the reduction of 95 index will be higher, because it is more close to natural light, the value of 80 will be relatively lower, so the lamp with a choice. This aspect also needs to be considered.

Color tolerance (SDCM) ≤2

The measured color tolerance is much higher than the national standard

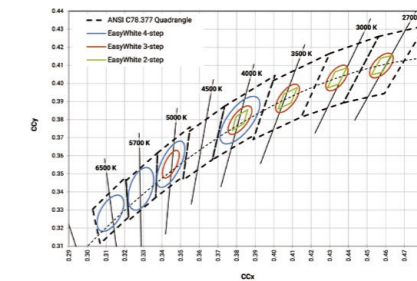

The ellipse can be interpreted as a Step, and the difference between 5 and 7 steps can be detected by the naked eye.

Industry standard level:

1. Energy Star ANSI C78.376, color tolerance ≤7 SDCM, divided by LED characteristics.
2. Eu standard ERP, color tolerance ≤6SDCM, in accordance with the specified technical requirements to standardize LED division.
3. national standard GB10682-2002, double end fluorescent lamp performance requirements of color tolerance ≤5 SDCM, can be used as a reference for LED lamp color tolerance requirements.

The implementation scheme of SDCM products with medium color tolerance ≤2

1. Improve the color concentration of the order, take the center point of color tolerance as the center point of the product color, and concentrate the color of the lamp beads within the range of the third order as far as possible;
2. For SMT and lumen imitation orders, the color tolerance of some products will fall into the range of order 3-5, which can be divided into bins according to the color tolerance difference optical mode, and the color tolerance of the whole lamp can be less than order 3 through the way of cross SMT. Photoelectric technicians of the same party can provide you with the best collocation scheme.

Human centered natural spectrum

Features	Advantages
The spectrum is carefully designed to accurately mimic natural light while reducing the intensity of blue light	A complete and consistent spectrum, with fewer peaks, is closest to natural light.
Natural and vivid color reduction ability	CRI (R1-R15) mean 98, excellent TM-30 index (R1-R99), R (fidelity)96-98, R saturation 99-101.
The industry's most efficient natural spectrum	Light efficiency up to 132LM/W, more environmentally energy saving, reduce utility and environmental costs.
Affordable natural spectrum to optimize human health	Accelerate the full spread of the natural spectrum
No ultraviolet light harmful to the human body or objects	Improves reliability and service life
Full platform design, including COB, patch SMD, dual color temperature module, and other options.	Achieve design flexibility and product color consistency

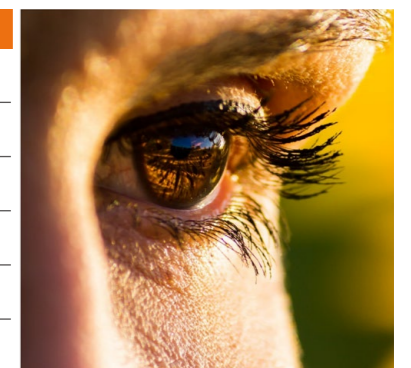

Application : Luxury houses, hotels, clubs, exhibition halls, office buildings, office areas, etc

Products Parameter

○ White
● Black

15° 24° 36° 50°

	ZX-THXQ-07	ZX-THXQ-12	ZX-THXQ-20	ZX-THXQ-40
Model No.	ZX-THXQ-07	ZX-THXQ-12	ZX-THXQ-20	ZX-THXQ-40
Power	7W	12W	20W	40W
Voltage	AC220-240V	AC220-240V	AC220-240V	AC220-240V
CCT	3000K/3500K/4000K/5000K	3000K/3500K/4000K/5000K	3000K/3500K/4000K/5000K	3000K/3500K/4000K/5000K
CRI	Ra≥95	Ra≥95	Ra≥95	Ra≥95
UGR	<13	<13	<13	<13
Flux	480Lm	900Lm	1450Lm	2800Lm
Size	Ø62*H90mm	Ø82*H92mm	Ø102*H116mm	L169*W85*H97mm
Cut-size	Ø55mm	Ø75mm	Ø95mm	L162*W81mm
IP Rate	IP 20	IP 20	IP 20	IP 20
Chip	bridgelux TOYANIA	bridgelux TOYANIA	bridgelux TOYANIA	bridgelux TOYANIA

Product size unit (mm)

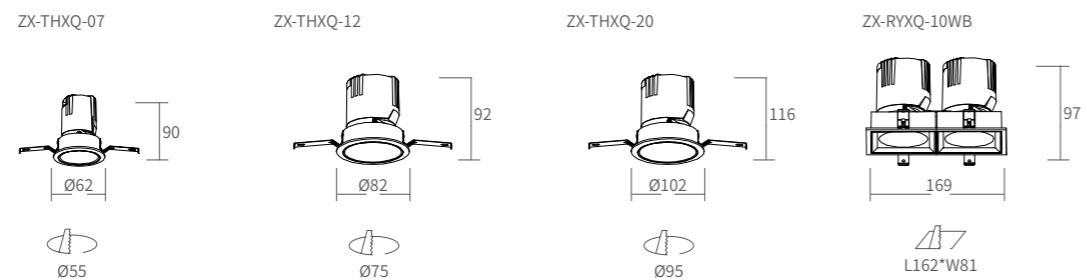

Optional Accessories



Optional Reflective Cup

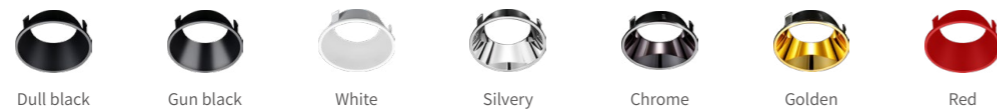

Smart function optional

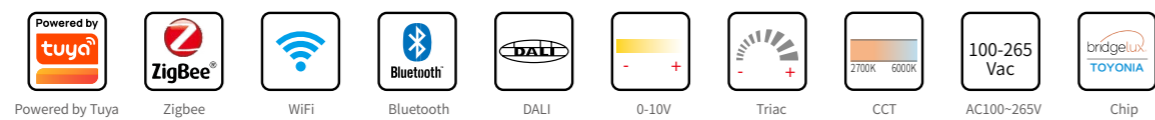

Application : Luxury houses, hotels, clubs, exhibition halls, office buildings, office areas, etc

Light distribution curve

ZX-THXQ-07

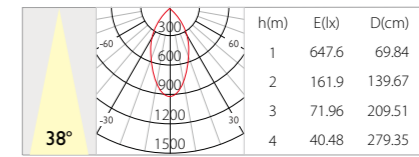
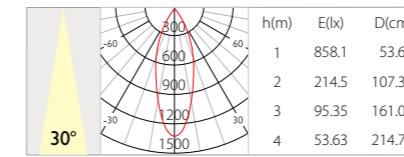
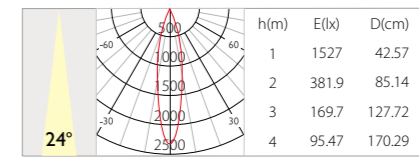
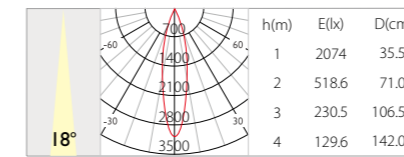

ZX-THXQ-12

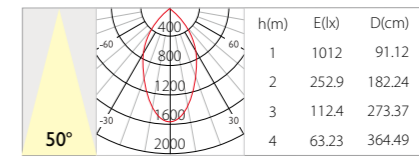
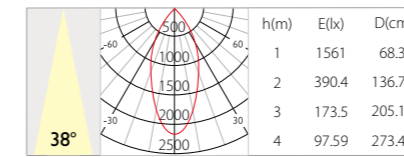
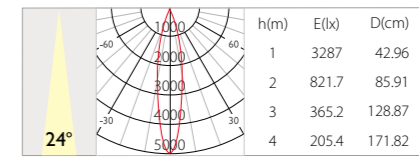
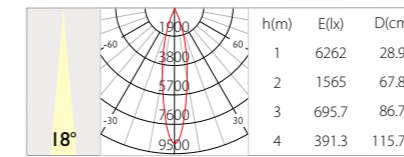

ZX-THXQ-20

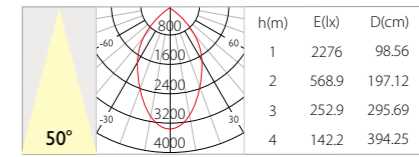
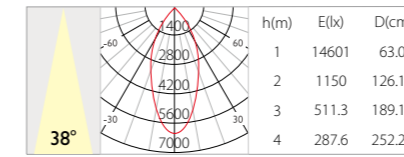
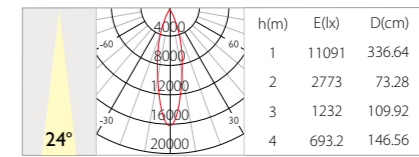
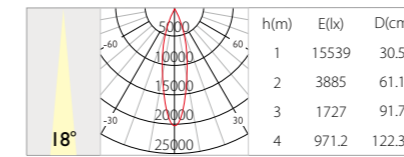

ZX-THXQ-40

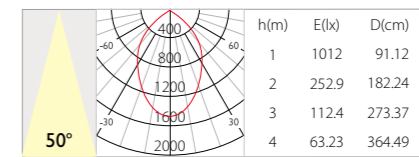
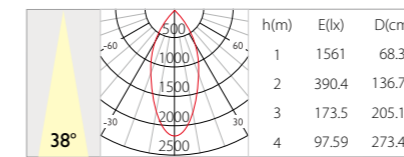
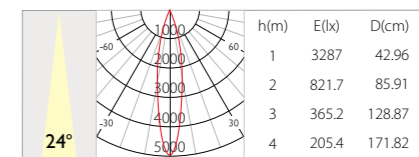
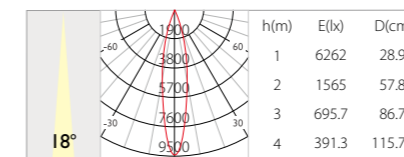

Application : Luxury houses, hotels, clubs, exhibition halls, office buildings, office areas, etc

Products Parameter

○ White
● Black

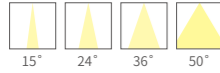

ZX-THXQ-07WB



ZX-THXQ-12WB



ZX-THXQ-20WB

Model No.	ZX-THXQ-07WB	ZX-THXQ-12WB	ZX-THXQ-20WB
Power	7W	12W	20W
Voltage	AC220-240V	AC220-240V	AC220-240V
CCT	3000K/3500K/4000K/5000K	3000K/3500K/4000K/5000K	3000K/3500K/4000K/5000K
CRI	Ra≥95	Ra≥95	Ra≥95
UGR	<13	<13	<13
Flux	480lm	900lm	1450lm
Size	Ø82*H90mm	Ø100*H92mm	Ø125*H116mm
Cut-size	Ø55mm	Ø75mm	Ø95mm
IP Rate	IP 20	IP 20	IP 20
Chip	CREE, Bridgelux, OSRAM	CREE, Bridgelux, OSRAM	CREE, Bridgelux, OSRAM

Product size
unit (mm)

ZX-THXQ-07WB

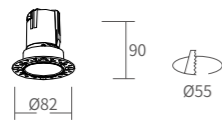

ZX-THXQ-12WB

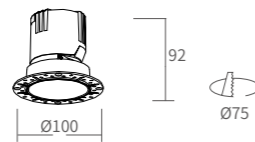

ZX-THXQ-20WB

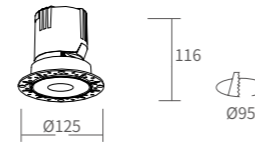

Optional Accessories



Honeycomb louver



Linear lens



Soft lens

Optional Reflective Cup



Dull black



Gun black



White



Silvery



Chrome



Golden



Red

Smart function optional



Powered by Tuya



Zigbee



WiFi



Bluetooth



DALI



0-10V



Triac



CCT



100-265V



Chip

Light distribution curve

ZX-THXQ-07WB

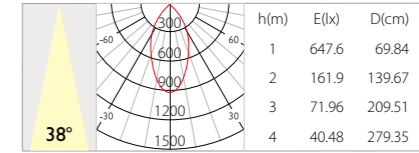
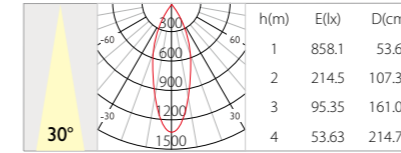
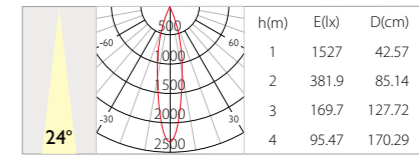
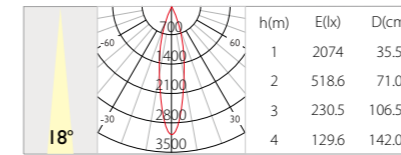

ZX-THXQ-12WB

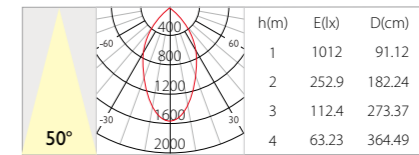
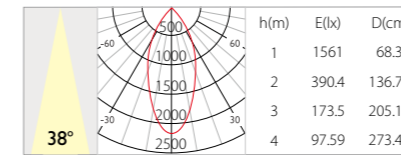
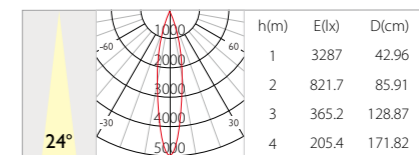
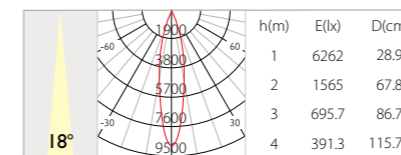

ZX-THXQ-20WB

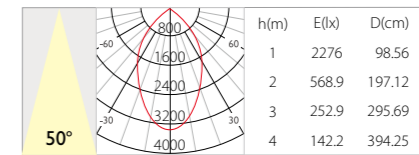
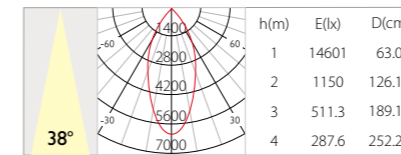
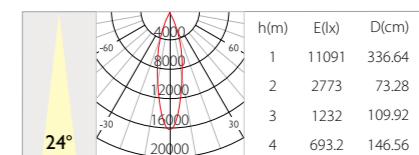
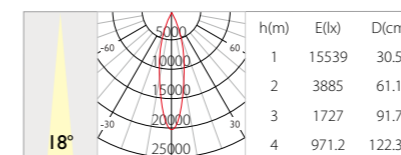

NIMBLE SERIES DOWNLIGHT

Automobile paint baking process
Upgrade surface treatment and fashionable texture



Application : Luxury houses, hotels, clubs, exhibition halls, office buildings, office areas, etc

DEEP LIGHT SOURCE IT IS TRUE TO SEE LIGHT BUT NO LAMP

The anti dazzle performance is improved by referring to the anti dazzle design of spotlights.
Don't worry about the dazzling light caused by the low floor height of the bathroom ceiling

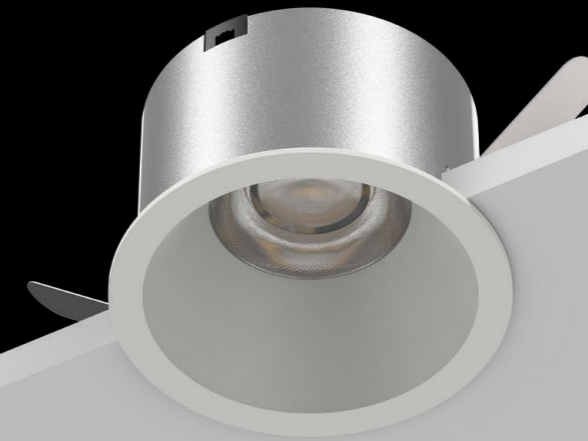

Wide projection area



Explicit height



Not dazzling

DETAILS EVERY LIGHT IS A BRIGHT SPOT

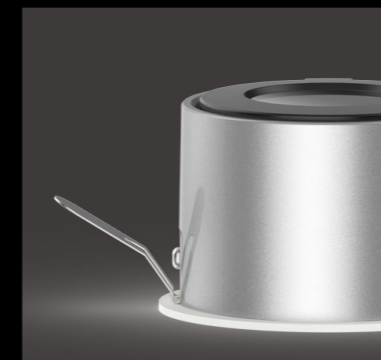

Automobile paint baking process
Upgrade surface treatment and
fashionable texture

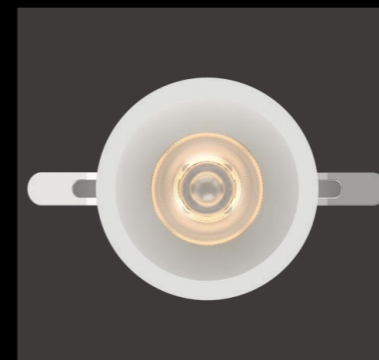

Significantly up to Ra90,
comparable to natural light



Efficient heat dissipation prolongs the
service life of lamps

Application : Luxury houses, hotels, clubs, exhibition halls, office buildings, office areas, etc



Product features

High Efficiency	CE Certification	UGR <19	HIGH CRI Ra>90
Smart Dimmable	IP20 Protection Level	Anti-glare cut off angle >30°	Different sizes
Eye protection without stroboscopic	High Quality LED Chip	Visual comfort	Customizable

Application : Luxury houses, hotels, clubs, exhibition halls, office buildings, office areas, etc

Products Parameter

- White
- Black



ZX-LDTD-05



ZX-LDTD-10



ZX-LDTD-15

Model No.	ZX-LDTD-05	ZX-LDTD-10	ZX-LDTD-15
Power	5W	10W	15W
Voltage	AC220-240V	AC220-240V	AC220-240V
CCT	3000K/3500K/4000K/6000K	3000K/3500K/4000K/6000K	3000K/3500K/4000K/6000K
CRI	Ra≥90	Ra≥90	Ra≥90
UGR	<13	<13	<13
Flux	350Lm	750Lm	1100Lm
Size	Ø60*H42mm	Ø80*H50mm	Ø100*H62mm
Cut-size	Ø55mm	Ø75mm	Ø95mm
IP Rate	IP 20	IP 20	IP 20
Chip			

Product size unit (mm)

ZX-LDTD-05

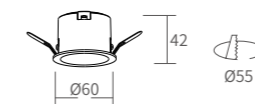

ZX-LDTD-10

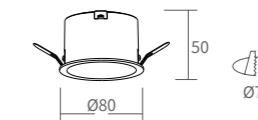

ZX-LDTD-15

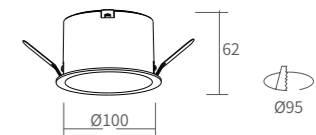

Optional Reflective Cup

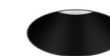

Black



White

Smart function optional



Powered by Tuya



Zigbee



WiFi



Bluetooth



DALI



0-10V



Triac



CCT



100-265 Vac



Chip

Application : Luxury houses, hotels, clubs, exhibition halls, office buildings, office areas, etc

Product features

- It is made of high-quality aluminum and Integrated molding technology.
- It is durable and exquisite in structure.
- Adopt high quality LED chip and lighting accessories to ensure the light effect.
- The triple anti-dazzle design creates a more comfortable light environment.
- Advanced thermal management technology ensures the continuity of maximum light output and the consistency of color temperature.
- It is suitable for hotels, shopping malls, clothing stores, offices, home and other lighting places.



Protection grade

IP54 dustproof and waterproof protection

X series products have built-in fully sealed protective cover, anti drag and moisture-proof screw structure, and 2 empty parts to protect the core parts of lamps in an all-round way, effectively prevent the invasion of foreign objects, moisture and water spray, and ensure the normal use of lamps in harsh environments.

Anti drag moisture-proof screw
The structure protects the power supply from damage

Sealing protective cover
Dustproof, waterproof and moisture proof

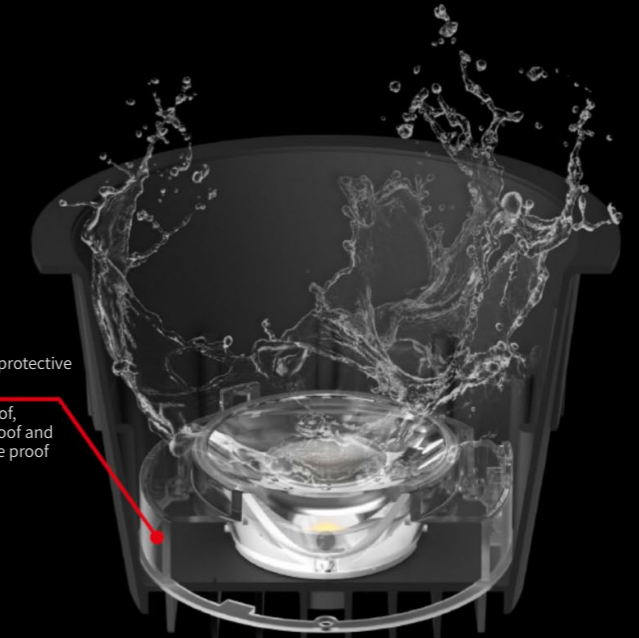

Triple anti-dazzle

The triple reflector cup and reflector are used together to refract the emitted light through the transparent cup and reflector to the reflective cup. After filtering, the light can reach the high standard comfort of $urg \leq 16$, greatly reduce the generation of glare and improve the user's comfort experience.

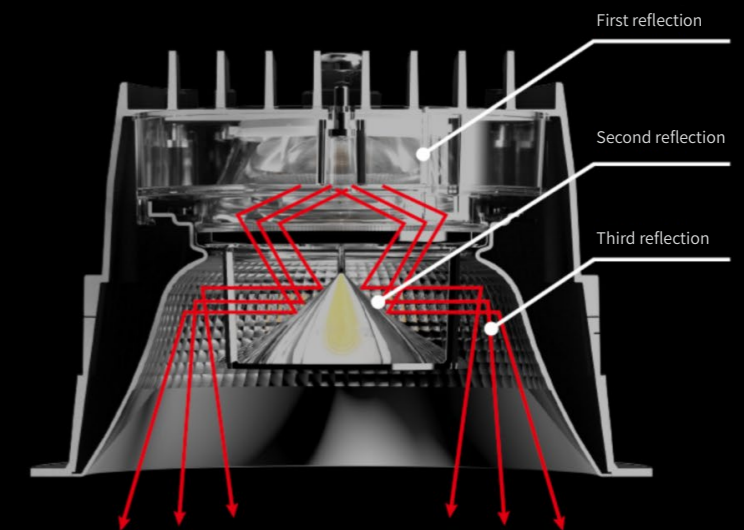

Multiple size selection

Multi size selection covers general space

9W / 15W / 24W / 35W / 40W various output powers are available, which is suitable for indoor space with floor height of less than 2 ~ 10m.

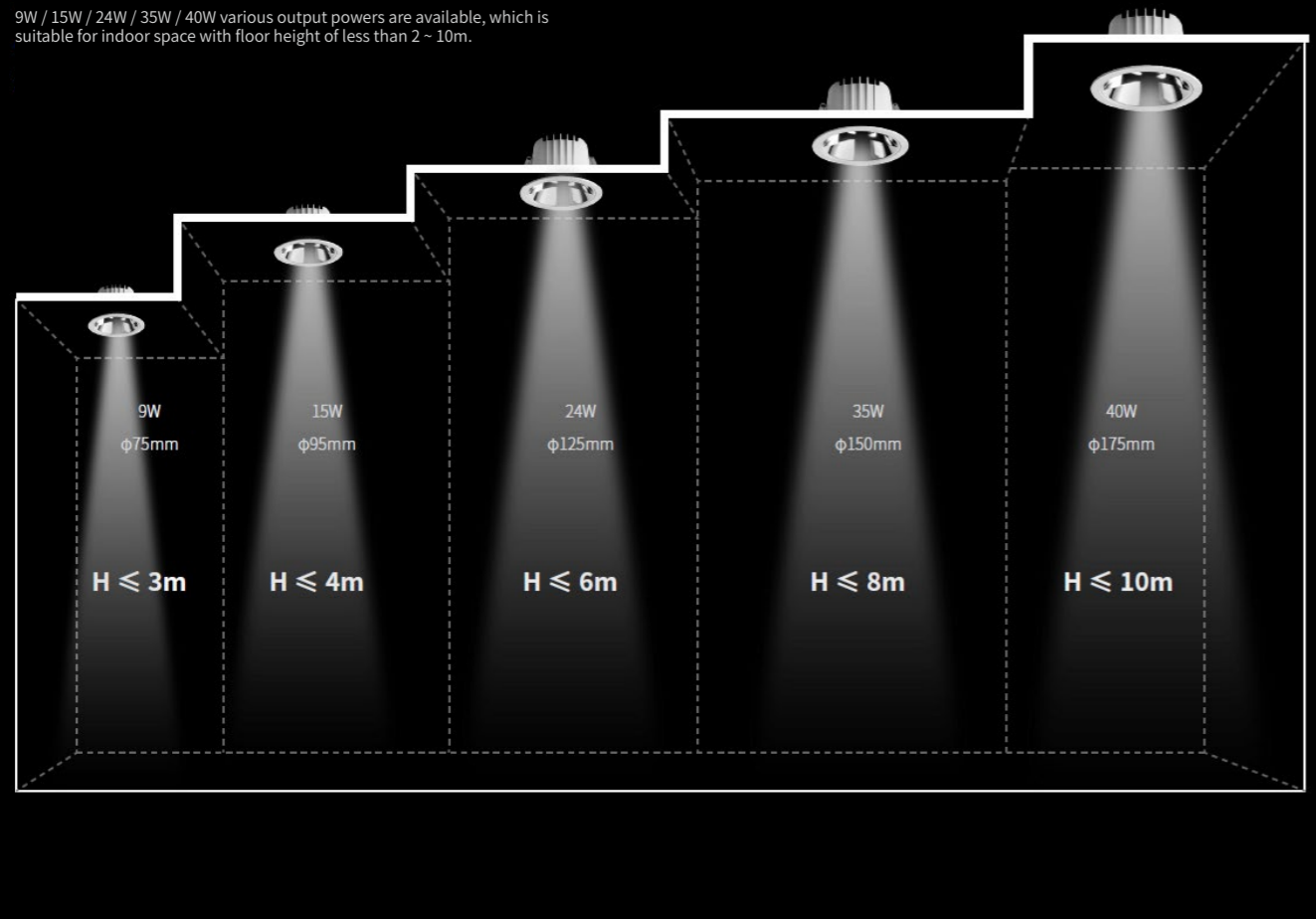

Smart function optional

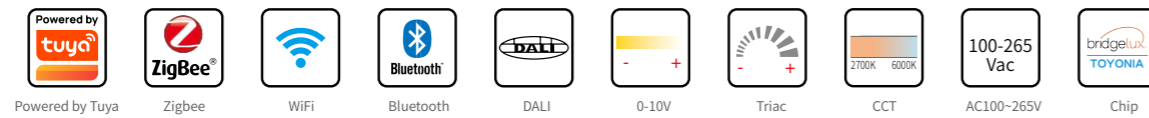

Product features

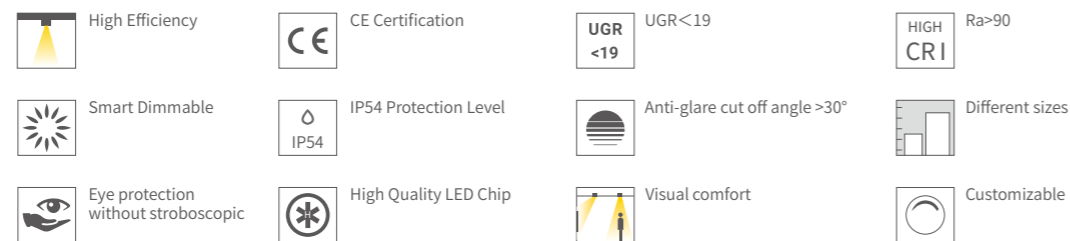

Application : Luxury houses, hotels, clubs, exhibition halls, office buildings, office areas, etc

Products Parameter

○ White
● Black



Model No.	ZX-GZTD-09	ZX-GZTD-15	ZX-GZTD-24	ZX-GZTD-35	ZX-GZTD-45
Power	9W	15W	24W	35W	45W
Voltage	AC220-240V 47Hz-63Hz	AC220-240V 47Hz-63Hz	AC220-240V 47Hz-63Hz	AC220-240V 47Hz-63Hz	AC220-240V 47Hz-63Hz
CCT	3000K/4000K/5000K/6000K	3000K/4000K/5000K/6000K	3000K/4000K/5000K/6000K	3000K/4000K/5000K/6000K	3000K/4000K/5000K/6000K
CRI	Ra≥90	Ra≥90	Ra≥90	Ra≥90	Ra≥90
UGR	<16	<16	<16	<16	<16
Flux	710Lm	1060Lm	1500Lm	2200Lm	2900Lm
Size	Ø87*H65mm	Ø110*H75mm	Ø135*H95mm	Ø160*H109mm	Ø186*H121mm
Cut-size	Ø75mm	Ø100mm	Ø125mm	Ø150mm	Ø175mm
IP Rate	IP 54	IP 54	IP 54	IP 54	IP 54
Chip	CREE OSRAM	CREE OSRAM	CREE OSRAM	CREE OSRAM	CREE OSRAM

Product size unit (mm)

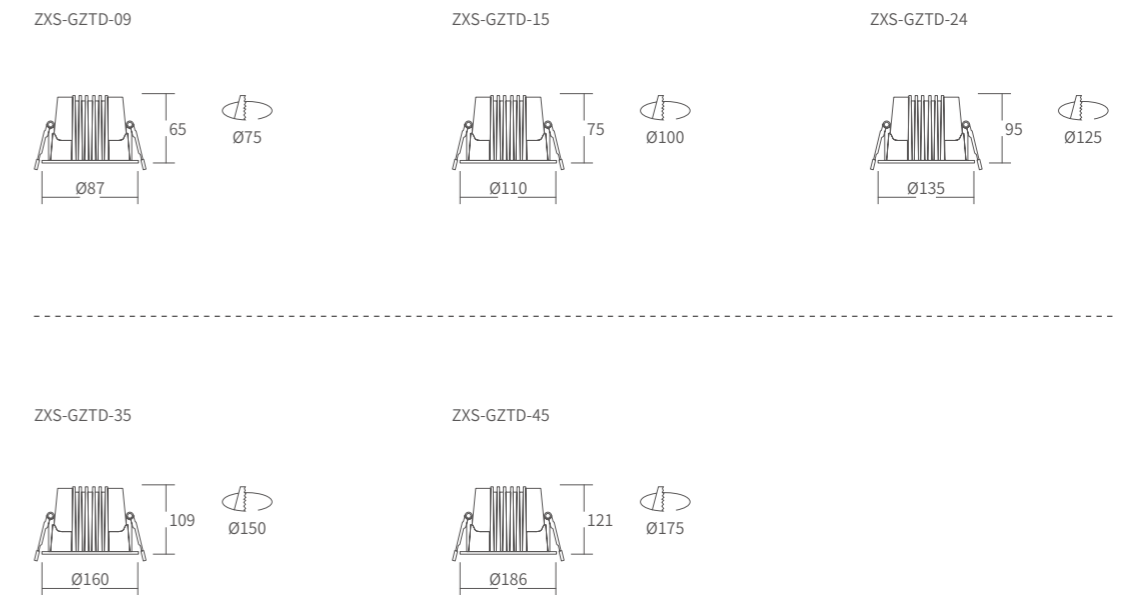

Optional Reflective Cup



Application : Luxury houses, hotels, clubs, exhibition halls, office buildings, office areas, etc

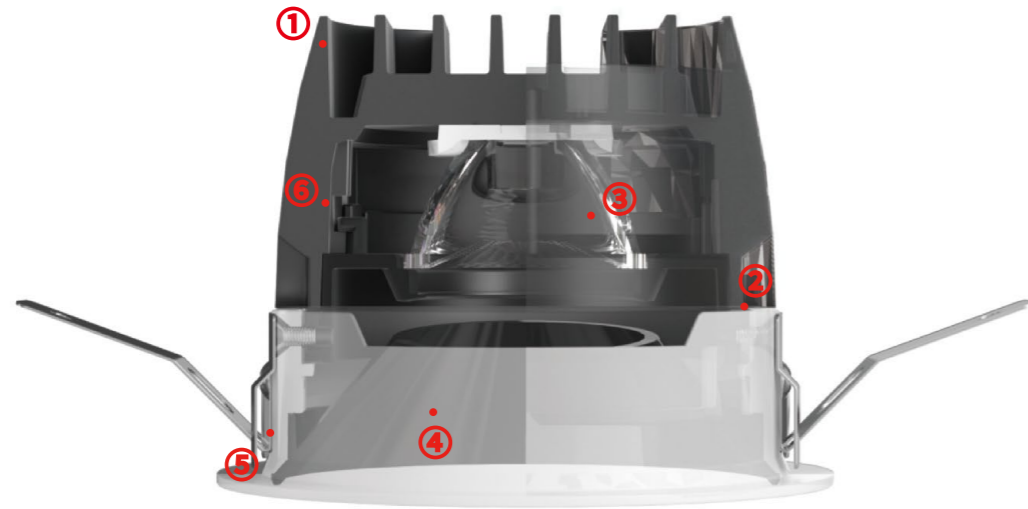

Product description

- 

① Modular cooling engine
The beautiful art design and chimney heat dissipation provide sufficient security for the stability of COB.
- 

② Direct illumination / adjustable integration
The structure can be switched freely and the function is perfect. Polarizing / trimless effective compatibility to reduce inventory.
- 

③ Infinite apricot remote optical module
Modular design, 6-50 degrees, 7 optical applications. Let the design have more possibilities and make the experience better.
- 

④ High precision secondary optical device
Mini small edge, precise light control, making rhyme light more natural. Private mold customization, ingenious design, more simple and fashionable.
- 

⑤ Impeccable snap mechanism
Effectively compatible with the installation environment of 1.5-20mm, efficient loading and unloading, without damaging the ceiling.
- 

⑥ Fine surface treatment
High precision CNC machining, twice grinding, electrostatic spraying. The product process quality can be seen and touched, and the texture is fully displayed.
- 







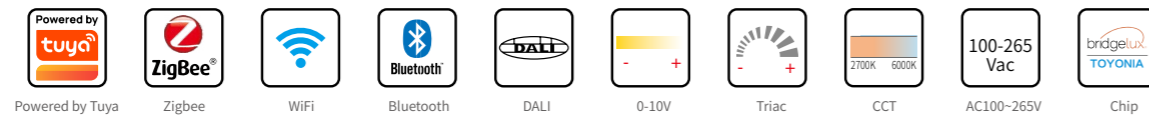





★ Thick anti dazzle, accurate light control, natural rhyme and light
UGR ≤ 19
- 

★ Small size, high efficiency, strong compatibility

Smart function optional



Product features

-  High Efficiency
-  CE Certification
-  UGR <19
-  HIGH CRI
-  Smart Dimmable
-  IP20 Protection Level
-  Anti-glare cut off angle >30°
-  Different sizes
-  Eye protection without stroboscopic
-  High Quality LED Chip
-  Visual comfort
-  Customizable

Application : Luxury houses, hotels, clubs, exhibition halls, office buildings, office areas, etc

Products Parameter

- White
- Black

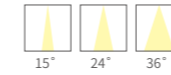

Model No.	ZX-RYAO-55	ZX-RYAO-75
Power	6W	10W
Voltage	AC110-240V	AC110-240V
CCT	3000K/4000K/5000K/6000K	3000K/4000K/5000K/6000K
CRI	Ra ≥ 90	Ra ≥ 90
UGR	<19	<19
Flux	420Lm	710Lm
Size	Ø65*H49mm	Ø100*H65mm
Cut-size	Ø55mm	Ø75mm
IP Rate	IP 44	IP 44
Chip	CREE OSRAM	CREE OSRAM
Optional Accessories	 Mini narrow edge  Boundless embedding  Polarized wall washing	 Mini narrow edge  Boundless embedding  Polarized wall washing

Product size unit (mm)

ZX-RYAO-55

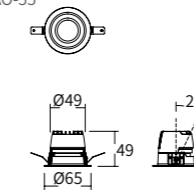

ZX-RYAO-75

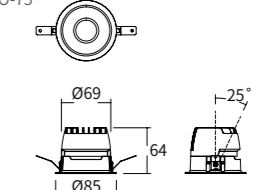

ZX-RYAO-55WB

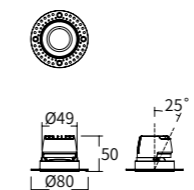

ZX-RYAO-75WB

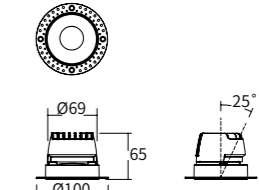

ZX-RYAO-55PG

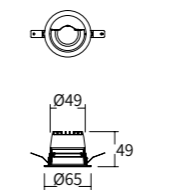

ZX-RYAO-75PG

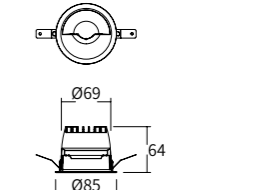

Optional Reflective Cup



Application : Luxury houses, hotels, clubs, exhibition halls, office buildings, office areas, etc



Smart function optional

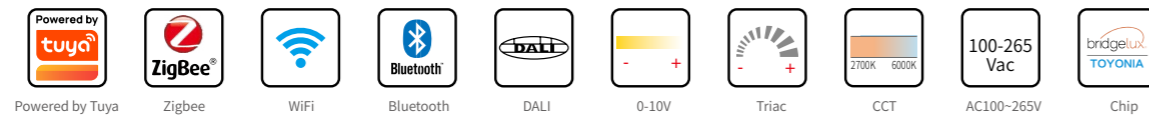

Product features

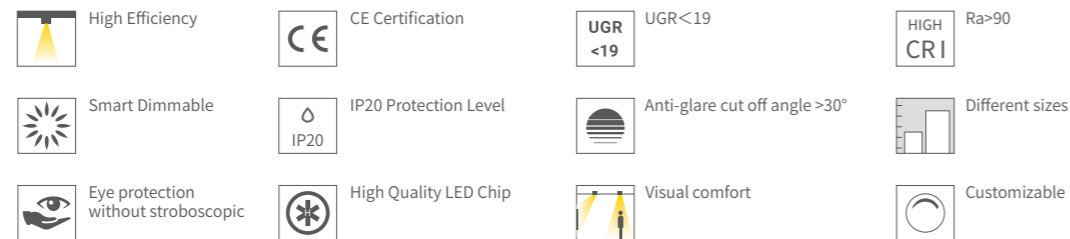

Application : Luxury houses, hotels, clubs, exhibition halls, office buildings, office areas, etc

Products Parameter

○ White
● Black

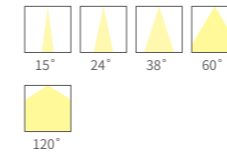

Model No.	ZX-GMSD-10	ZX-GMSD-12	ZX-GMSD-15	ZX-GMSD-18	ZX-GMSD-30
Power	10W	12W	15W	18W	30W
Voltage	AC220-240V 47Hz-63Hz	AC220-240V 47Hz-63Hz	AC220-240V 47Hz-63Hz	AC220-240V 47Hz-63Hz	AC220-240V 47Hz-63Hz
CCT	3000K/4000K/5000K/6000K	3000K/4000K/5000K/6000K	3000K/4000K/5000K/6000K	3000K/4000K/5000K/6000K	3000K/4000K/5000K/6000K
CRI	Ra≥90	Ra≥90	Ra≥90	Ra≥90	Ra≥90
UGR	<13	<13	<13	<13	<13
Flux	710Lm	850Lm	1060Lm	1280Lm	2100Lm
Size	Ø90*H56mm	Ø95*H60mm	Ø105*H64mm	Ø130*H72mm	Ø160*H82mm
Cut-size	Ø75mm	Ø80mm	Ø95mm	Ø120mm	Ø145mm
IP Rate	IP 20	IP 20	IP 20	IP 20	IP 20
Chip	CREE bridgeLux	CREE bridgeLux	CREE bridgeLux	CREE bridgeLux	CREE bridgeLux

Product size unit (mm)

ZX-GMSD-10

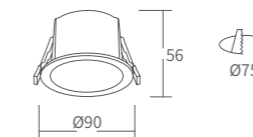

ZX-GMSD-12

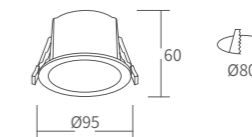

ZX-GMSD-15

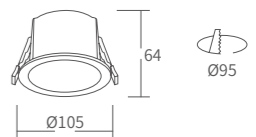

ZX-GMSD-18

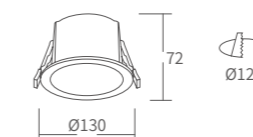

ZX-GMSD-30

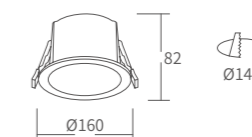

Optional Reflective Cup

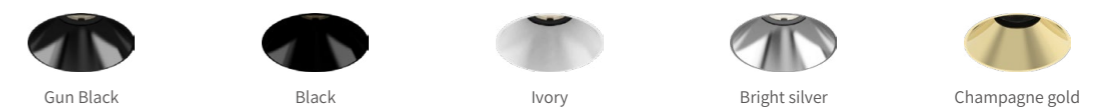

Application : Luxury houses, hotels, clubs, exhibition halls, office buildings, office areas, etc



Product features

High Efficiency	CE Certification	UGR <19	HIGH CRI Ra>90
Smart Dimmable	IP20 Protection Level	Anti-glare cut off angle >30°	Different sizes
Eye protection without stroboscopic	High Quality LED Chip	Visual comfort	Customizable

Application : Luxury houses, hotels, clubs, exhibition halls, office buildings, office areas, etc

Products Parameter

- White
- Black

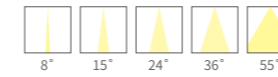

ZX-LINL-YX01



ZX-LINL-FX01



ZX-LINL-FX02

Model No.	ZX-LINL-YX01	ZX-LINL-FX01	ZX-LINL-FX02
Power	12W	12W	12W*2
Voltage	AC220-240V	AC220-240V	AC220-240V
CCT	3000K/4000K/5000K/6000K	3000K/4000K/5000K/6000K	3000K/4000K/5000K/6000K
CRI	Ra≥92	Ra≥92	Ra≥92
UGR	<13	<13	<13
Flux	820Lm	820Lm	1620Lm
Size	Ø85*H52mm	L85*W85*H52mm	L170*W85*H52mm
Cut-size	Ø75mm	L75*W75mm	L75*W160mm
IP Rate	IP 20	IP 20	IP 20
Chip			

Product size unit (mm)

ZX-LINL-YX01

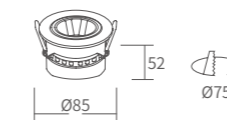

ZX-LINL-FX01

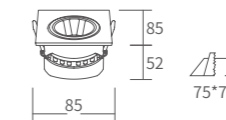

ZX-LINL-FX02

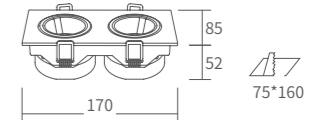

Optional Reflective Cup



Black



Ivory

Smart function optional



Powered by Tuya



Zigbee



WiFi



Bluetooth



DALI



0-10V



Triac



CCT



AC100-265V



Chip

Application : Luxury houses, hotels, clubs, exhibition halls, office buildings, office areas, etc



Products Parameter

- White
- Black

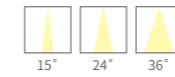

ZX-YUYI-YX01



ZX-YUYI-FX01



ZX-YUYI-FX02



ZX-YUYI-FX03

Model No.	ZX-YUYI-YX01	ZX-YUYI-FX01	ZX-YUYI-FX02	ZX-YUYI-FX03
Power	7W	7W	7W*2	7W*3
Voltage	AC220-240V	AC220-240V	AC220-240V	AC220-240V
CCT	3000K/4000K/5000K/6000K	3000K/4000K/5000K/6000K	3000K/4000K/5000K/6000K	3000K/4000K/5000K/6000K
CRI	Ra≥90	Ra≥90	Ra≥90	Ra≥90
UGR	<13	<13	<13	<13
Flux	480Lm	480Lm	960Lm	1320Lm
Size	Ø85*H35mm	L85*W85*H67mm	L170*W85*H35mm	L247*W85*H35mm
Cut-size	Ø75mm	L75*W75mm	L75*W160mm	L75*W235mm
IP Rate	IP 20	IP 20	IP 20	IP 20
Chip	CREE OSRAM	CREE OSRAM	CREE OSRAM	CREE OSRAM

Product size unit (mm)

ZX-YUYI-YX01

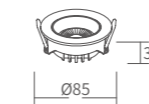

ZX-YUYI-FX01

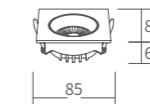

ZX-YUYI-FX02

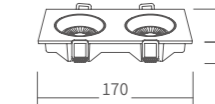

ZX-YUYI-FX03

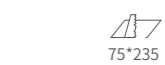
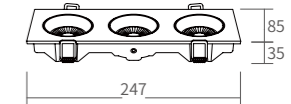

Optional Reflective Cup



Black



Ivory

Product features

High Efficiency	CE Certification	UGR <19	HIGH CRI Ra>90
Smart Dimmable	IP20 Protection Level	Anti-glare cut off angle >30°	Different sizes
Eye protection without stroboscopic	High Quality LED Chip	Visual comfort	Customizable

Application : Luxury houses, hotels, clubs, exhibition halls, office buildings, office areas, etc

Smart function optional

Powered by Tuya	Zigbee	WiFi	Bluetooth	DALI	0-10V	Triac	CCT	100-265 Vac	Chip
-----------------	--------	------	-----------	------	-------	-------	-----	-------------	------

Application : Luxury houses, hotels, clubs, exhibition halls, office buildings, office areas, etc



Product features

High Efficiency	CE Certification	UGR <19	HIGH CRI Ra>90
Smart Dimmable	IP20 Protection Level	Anti-glare cut off angle >30°	Different sizes
Eye protection without stroboscopic	High Quality LED Chip	Visual comfort	Customizable

Application : Luxury houses, hotels, clubs, exhibition halls, office buildings, office areas, etc

Products Parameter

- White
- Black

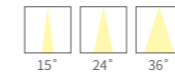

ZX-ML-YX01



ZX-ML-FX01



ZX-ML-FX02



ZX-ML-FX03

Model No.	ZX-ML-YX01	ZX-ML-FX01	ZX-ML-FX02	ZXS-ML-FX03
Power	12W	12W	12W*2	12W*3
Voltage	AC220-240V	AC220-240V	AC220-240V	AC220-240V
CCT	3000K/4000K/5000K/6000K	3000K/4000K/5000K/6000K	3000K/4000K/5000K/6000K	3000K/4000K/5000K/6000K
CRI	Ra≥90	Ra≥90	Ra≥90	Ra≥90
UGR	<13	<13	<13	<13
Flux	820Lm	820Lm	1620Lm	2320Lm
Size	Ø87*H67mm	L84*W84*H67mm	L167*W84*H67mm	L250*W84*H67mm
Cut-size	Ø75mm	L75*W75mm	L75*W155mm	L75*W230mm
IP Rate	IP 20	IP 20	IP 20	IP 20
Chip				

Product size unit (mm)

ZX-ML-YX01

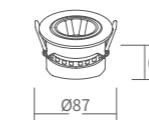

ZX-ML-FX01

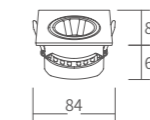

ZX-ML-FX02

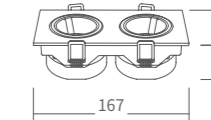

ZX-ML-FX03

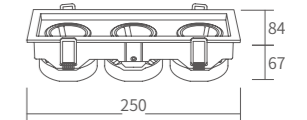

Optional Reflective Cup



Gun Black



Black



White



Silver

Smart function optional



Powered by Tuya



Zigbee



WiFi



Bluetooth



DALI



0-10V



Triac



CCT



AC100-265V



Chip

Application : Luxury houses, hotels, clubs, exhibition halls, office buildings, office areas, etc

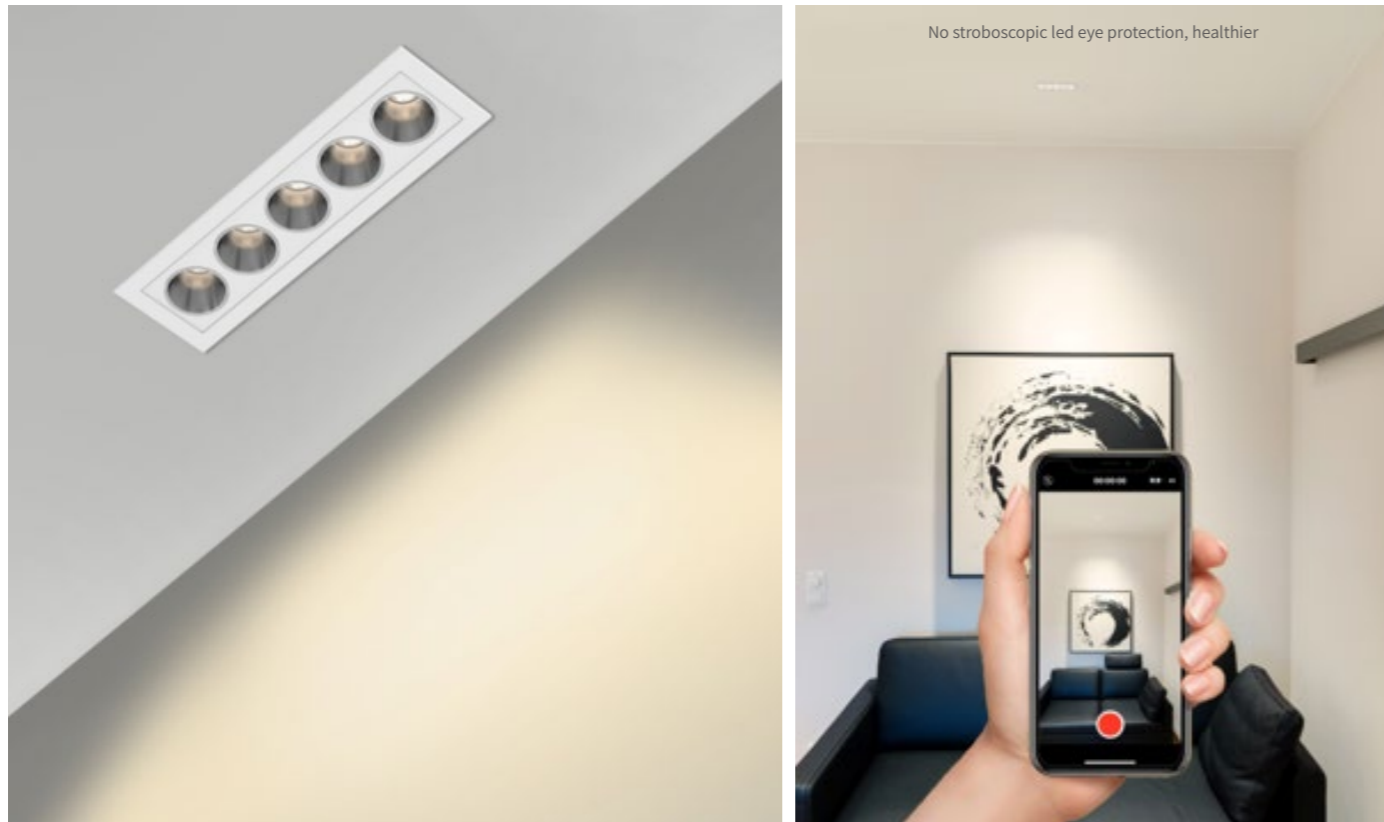

Installation mode

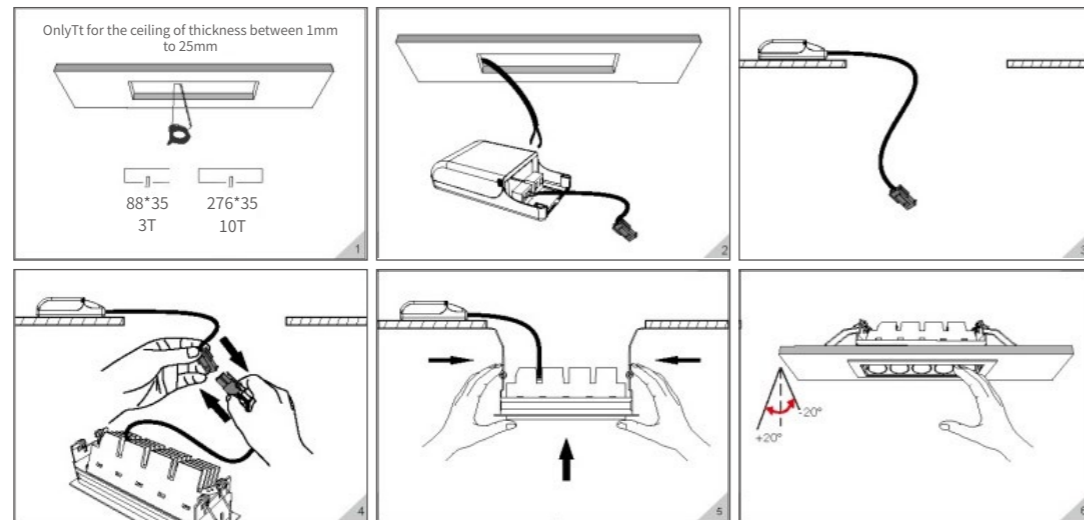

Product features

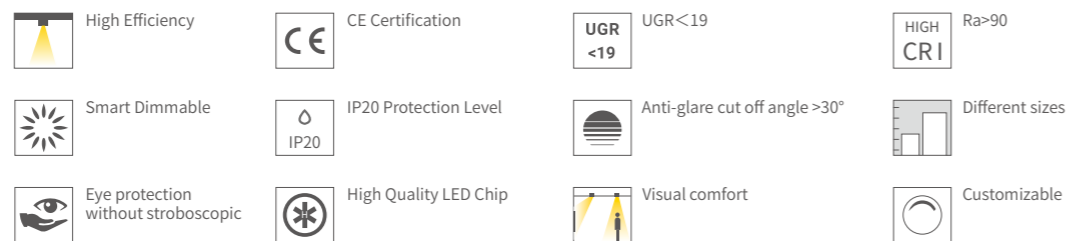

Application : Luxury houses, hotels, clubs, exhibition halls, office buildings, office areas, etc

Products Parameter

- White
- Black

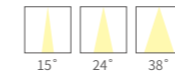

ZX-GSXT-1T



ZX-GSXT-2T



ZX-GSXT-3T



ZX-GSXT-4T

Model No.	ZX-GSXT-1T	ZX-GSXT-2T	ZX-GSXT-3T	ZX-GSXT-4T
Power	2W	4W	6W	8W
Voltage	AC220-240V	AC220-240V	AC220-240V	AC220-240V
CCT	3000K/4000K/6000K	3000K/4000K/6000K	3000K/4000K/6000K	3000K/4000K/6000K
CRI	Ra≥90	Ra≥90	Ra≥90	Ra≥90
UGR	<13	<13	<13	<13
Flux	150Lm	290Lm	450Lm	850Lm
Size	L46*W46*H52mm	L69*W46*H52mm	L96*W46*H52mm	L76*W76*H52mm
Cut-size	L38*W38mm	L60*W35mm	L88*W35mm	L68*W68mm
IP Rate	IP 20	IP 20	IP 20	IP 20
Chip	OSRAM	OSRAM	OSRAM	OSRAM

Product size unit (mm)

ZX-GSXT-1T

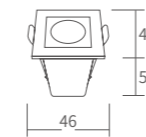

ZX-GSXT-2T

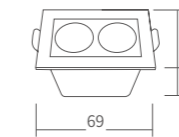

ZX-GSXT-3T

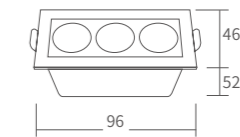

ZX-GSXT-4T

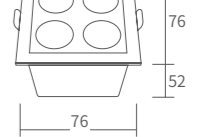

Optional Reflective Cup



Black



Champagne gold



White



Silver

Smart function optional



Powered by Tuya



Zigbee



WiFi



Bluetooth



DALI



0-10V



Triac



CCT



AC100-265V



Chip

Application : Luxury houses, hotels, clubs, exhibition halls, office buildings, office areas, etc



Product features

High Efficiency	CE Certification	UGR <19	HIGH CRI Ra>90
Smart Dimmable	IP20 Protection Level	Anti-glare cut off angle >30°	Different sizes
Eye protection without stroboscopic	High Quality LED Chip	Visual comfort	Customizable

Application : Luxury houses, hotels, clubs, exhibition halls, office buildings, office areas, etc

Products Parameter

- White
- Black

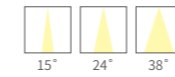

	ZX-GSXT-5T	ZX-GSXT-9T	ZX-GSXT-10T	ZX-GSXT-15T
Model No.	ZX-GSXT-5T	ZX-GSXT-9T	ZX-GSXT-10T	ZX-GSXT-15T
Power	10W	18W	20W	30W
Voltage	AC220-240V	AC220-240V	AC220-240V	AC220-240V
CCT	3000K/4000K/6000K	3000K/4000K/6000K	3000K/4000K/6000K	3000K/4000K/6000K
CRI	Ra≥90	Ra≥90	Ra≥90	Ra≥90
UGR	<13	<13	<13	<13
Flux	750Lm	1350Lm	1450Lm	2250Lm
Size	L148*W46*H52mm	L106*W46*H52mm	L285*W46*H52mm	L417*W46*H52mm
Cut-size	L140*W35mm	L98*W35mm	L276*W35mm	L408*W35mm
IP Rate	IP 20	IP 20	IP 20	IP 20
Chip	OSRAM	OSRAM	OSRAM	OSRAM

Product size unit (mm)

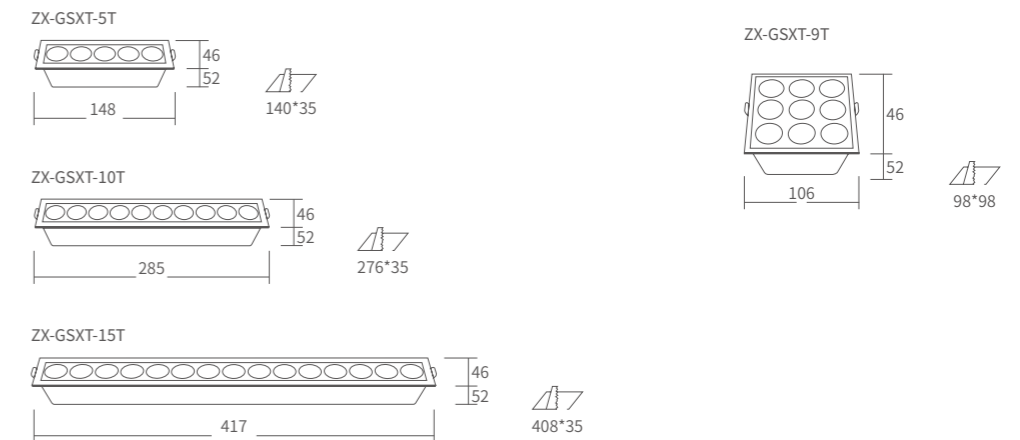

Optional Reflective Cup



Smart function optional

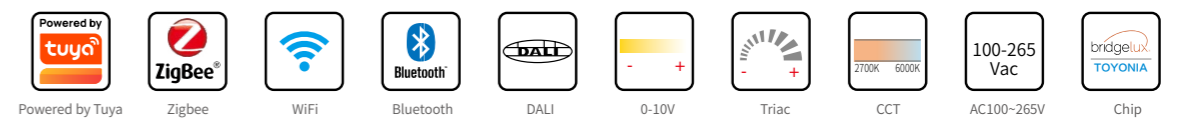

Application : Luxury houses, hotels, clubs, exhibition halls, office buildings, office areas, etc

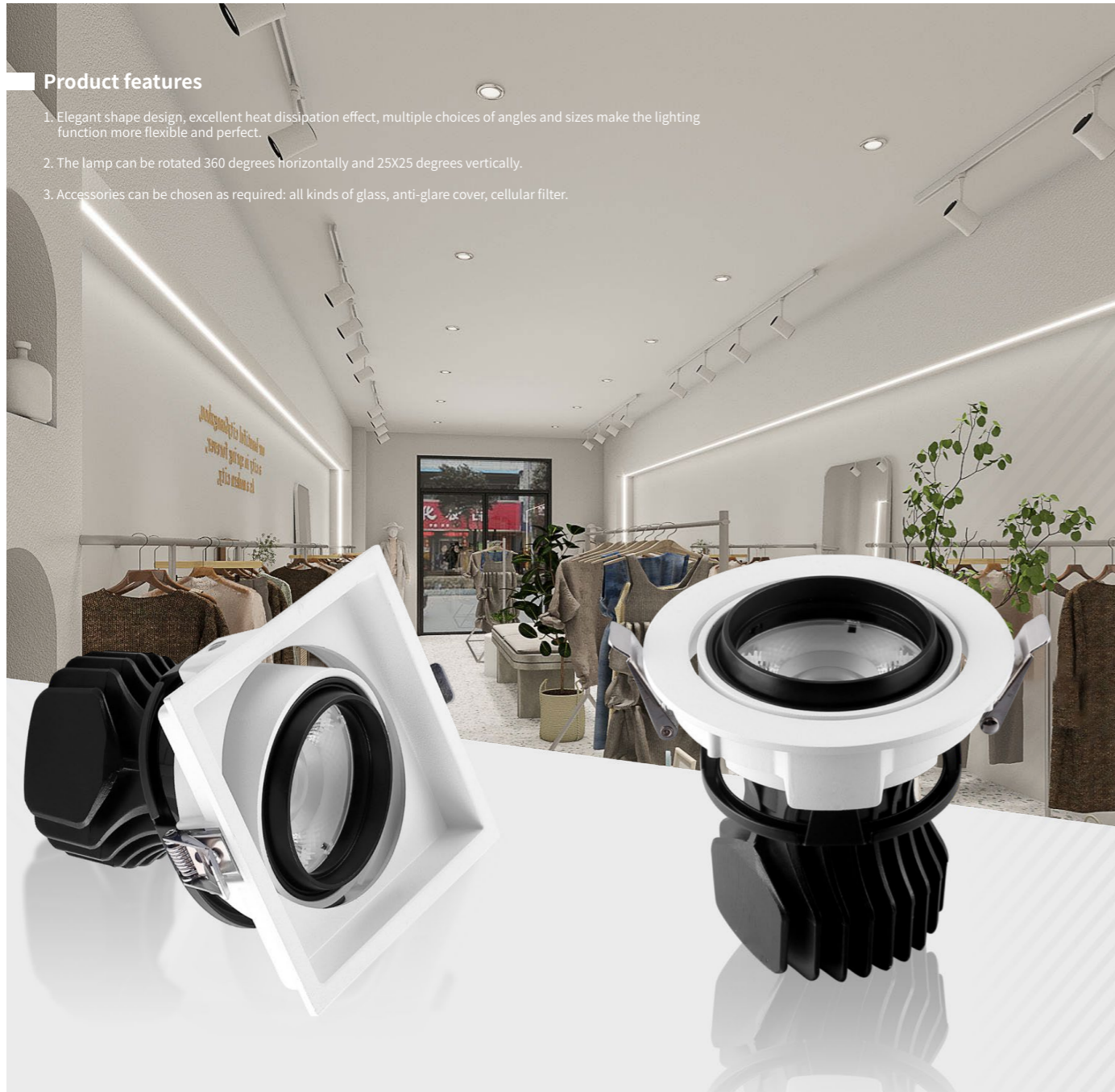

Product features

1. Elegant shape design, excellent heat dissipation effect, multiple choices of angles and sizes make the lighting function more flexible and perfect.
2. The lamp can be rotated 360 degrees horizontally and 25X25 degrees vertically.
3. Accessories can be chosen as required: all kinds of glass, anti-glare cover, cellular filter.

Products Parameter



ZX-360SD-20



ZX-360SD-30



ZX-360SD-36

- White
- Black

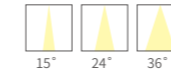

ZX-360SD-20F



ZX-360SD-30F



ZX-360SD-36F

Model No.	ZX-360SD-20/ZX-360SD-20F	ZX-360SD-30/ZX-360SD-30F	ZX-360SD-36/ZX-360SD-36F
Power	20W	30W	36W
Voltage	AC220V	AC220V	AC220V
CCT	3000K/3500K/4000K	3000K/3500K/4000K	3000K/3500K/4000K
CRI	Ra≥90	Ra≥90	Ra≥90
UGR	<19	<19	<19
Flux	1450Lm	2150Lm	2550Lm
Size	Ø65*H49mm/L105*W105*H115mm	Ø100*H65mm/L120*W120*H130mm	Ø120*H85mm/L150*W150*H152mm
Cut-size	Ø55mm/L95*W95mm	Ø75mm/L110*W110mm	Ø95mm/L140*W140mm
IP Rate	IP 20	IP 20	IP 20
Chip	CREE LUMINUS	CREE LUMINUS	CREE LUMINUS

Product size unit (mm)

ZX-360SD-20

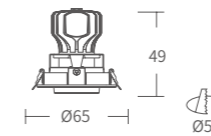

ZX-360SD-30

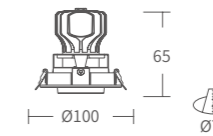

ZX-360SD-36

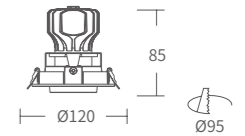

ZX-360SD-20F

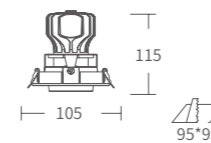

ZX-360SD-30F

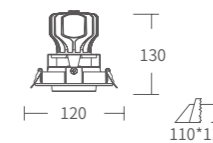

ZX-360SD-36F

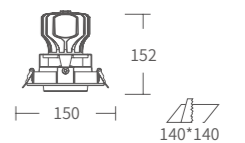

Product features

High Efficiency	CE Certification	UGR <19	HIGH CRI Ra>90
Smart Dimmable	IP20 Protection Level	Anti-glare cut off angle >30°	Different sizes
Eye protection without stroboscopic	High Quality LED Chip	Visual comfort	Customizable

Smart function optional

Powered by Tuya	ZigBee	WiFi	Bluetooth	DALI	0-10V	Triac	CCT	100-265 Vac	Chip
-----------------	--------	------	-----------	------	-------	-------	-----	-------------	------



Product features

- High Efficiency
- CE Certification
- UGR <19
- HIGH CRI Ra>90
- Smart Dimmable
- IP20 Protection Level
- Anti-glare cut off angle >30°
- Different sizes
- Eye protection without stroboscopic
- High Quality LED Chip
- Visual comfort
- Customizable

Application : Luxury houses, hotels, clubs, exhibition halls, office buildings, office areas, etc

Products Parameter

	ZX-LSSD-18	ZX-LSSD-25	ZX-LSSD-30
○ White ● Black	ZX-LSSD-18F	ZX-LSSD-25F	ZX-LSSD-30F
15°	24°	36°	
Model No.	ZX-LSSD-18/ZX-LSSD-18F	ZX-LSSD-25/ZX-LSSD-25F	ZX-LSSD-30/ZX-LSSD-30F
Power	18W	25W	30W
Voltage	AC220V	AC220V	AC220V
CCT	3000K/3500K/4000K	3000K/3500K/4000K	3000K/3500K/4000K
CRI	Ra≥90	Ra≥90	Ra≥90
UGR	<19	<19	<19
Flux	1250Lm	1750Lm	2150Lm
Size	Ø120*H130mm/L120*W120*H131mm	Ø130*H163mm/L135*W135*H163mm	Ø150*H176mm/L150*W150*H176mm
Cut-size	Ø110mm/L110*W110mm	Ø125mm/L125*W125mm	Ø140mm/L140*W140mm
IP Rate	IP 20	IP 20	IP 20
Chip			

Product size unit (mm)

ZX-LSSD-18

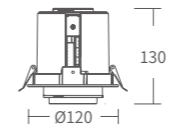

ZX-LSSD-25

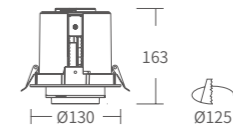

ZX-LSSD-30

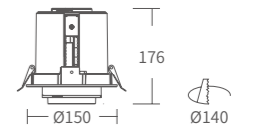

ZX-LSSD-18F

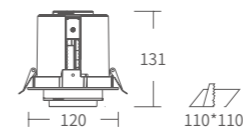

ZX-LSSD-25F

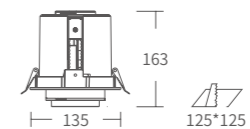

ZX-LSSD-30F

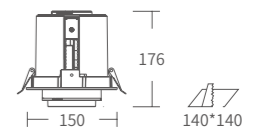

Smart function optional

- Powered by Tuya
- Zigbee
- WiFi
- Bluetooth
- DALI
- 0-10V
- Triac
- CCT
- 100-265 Vac
- Chip

Application : Luxury houses, hotels, clubs, exhibition halls, office buildings, office areas, etc



PRODUCT FEATURES

- Magnetic track lights can be assembled and combined freely, by laying the magnetic track, you can match to increase or decrease magnetic lamps and move them onto the track freely. The magnetic track lights are based on high anti-dazzle design (UGR < 13) with extremely visual comfort.
- We choose international brands CREE, OSRAM, Bridgelux imported LED chips, with high degree of color reduction, a variety of color temperature selection (high color rendering, true restoration color, color tolerance < 3 to ensure consistency of space color temperature and with adjustable dual-color temperature, to make sure the space atmosphere is flexible and dynamic.
- It has the advantage of more soft dimming with smart lighting system, logarithmic dimming curve, no stroboscopic, depth dimming 0.1%, standby power consumption is less 3mA.
- Convenient installation and maintenance, we add structural locking device on the basis of magnetic installation, to increase safety and stability
- With 48V safe voltage, the light can be direct contacted with power on.
- European CE and ROHS certification applied



**MAGNETIC
TRACK LIGHT
SERIES**



Configurable with Zigbee, wireless 2.4G, Bluetooth, 0-10V, DALI, TRIAC



Voice control



Products Parameter

● Black

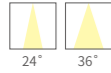

ZX-M20CXZD-T6



ZX-M20CXZD-T12

Model No.	ZX-M20CXZD-T6	ZX-M20CXZD-T12
Power	6W	12W
Voltage	DC48V	DC48V
CCT	3000K/4000K/6000K	3000K/4000K/6000K
CRI	Ra≥90	Ra≥90
UGR	<19	<19
Flux	450Lm	850Lm
Size	L112*W22*H95	L220*W22*H95
IP Rate	IP 20	IP 20
Chip	OSRAM	OSRAM

Product size unit (mm)

ZX-M20CXZD-T6

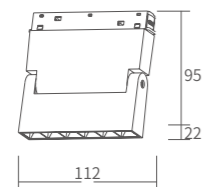

ZX-M20CXZD-T12

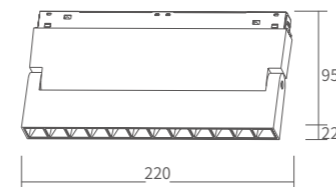

Products Parameter

● Black

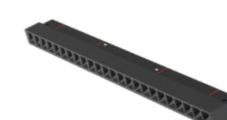

ZX-M20CXGS-T6

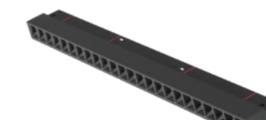

ZX-M20CXGS-T12

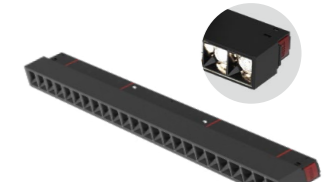

ZX-M20CXGS-T18

Model No.	ZX-M20CXGS-T6	ZX-M20CXGS-T12	ZX-M20CXGS-T18
Power	6W	12W	15W
Voltage	DC48V	DC48V	DC48V
CCT	3000K/4000K/6000K	3000K/4000K/6000K	3000K/4000K/6000K
CRI	Ra≥90	Ra≥90	Ra≥90
Flux	450Lm	850Lm	1050Lm
Size	L112*W23*H44	L220*W23*H44	L328*W23*H44
IP Rate	IP 20	IP 20	IP 20
Chip	OSRAM	OSRAM	OSRAM

Product size unit (mm)

ZX-M20CXGS-T6

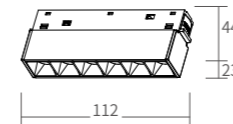

ZX-M20CXGS-T12

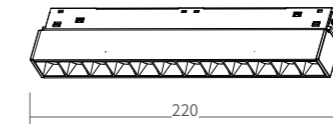

ZX-M20CXGS-T18

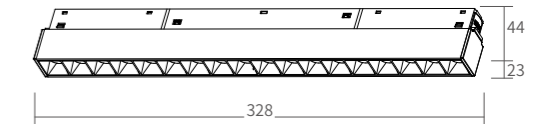

M20 ROTARY FOLDING LIGHT A SERIES

Products Parameter

● Black

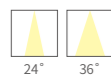

ZX-M20CXZD-T6A



ZX-M20CXZD-T12A

Model No.	ZX-M20CXZD-T6A	ZX-M20CXZD-T12A
Power	6W	12W
Voltage	DC48V	DC48V
CCT	3000K/4000K/6000K	3000K/4000K/6000K
CRI	Ra≥90	Ra≥90
UGR	<19	<19
Flux	450Lm	850Lm
Size	L112*W22*H95mm	L235*W33*H75mm
IP Rate	IP 20	IP 20
Chip	OSRAM	OSRAM

Product size unit (mm)

ZX-M20CXZD-T6A

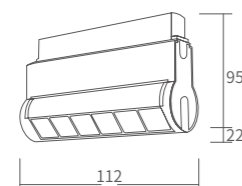

ZX-M20CXZD-T12A

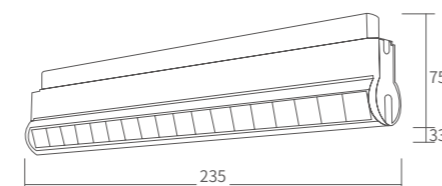

MAGNETIC TRACK LIGHT - M20 FLOODLIGHT SERIES

Products Parameter

● Black

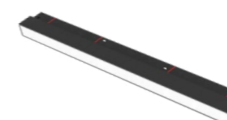

ZX-M20CXFG-T18

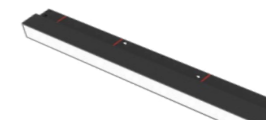

ZX-M20CXFG-T36

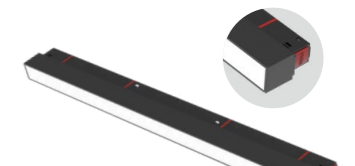

ZX-M20CXFG-T54

Model No.	ZX-M20CXFG-T18	ZX-M20CXFG-T36	ZX-M20CXFG-T54
Power	12W	24W	36W
Voltage	DC48V	DC48V	DC48V
CCT	3000K/4000K/6000K	3000K/4000K/6000K	3000K/4000K/6000K
CRI	Ra≥90	Ra≥90	Ra≥90
Flux	1200Lm	1800Lm	2500Lm
Size	L300*W23*H44	L600*W23*H44	L900*W23*H44
IP Rate	IP 20	IP 20	IP 20
Chip	OSRAM	OSRAM	OSRAM

Product size unit (mm)

ZX-M20CXFG-T18

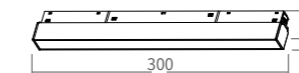

ZX-M20CXFG-T36

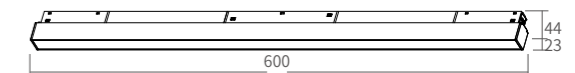

ZX-M20CXFG-T54

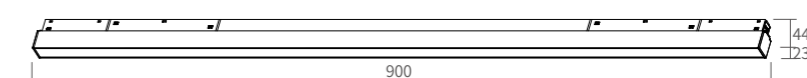

Products Parameter

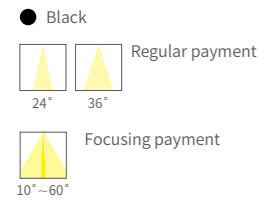

Model No.	ZX-M20CXDG-10	ZX-M20CXDG-20	ZX-M20CXDGTJ-10	ZX-M20CXDGTJ-20
Power	10W	18W	10W	18W
Voltage	DC48V	DC48V	DC48V	DC48V
CCT	3000K/4000K/6000K	3000K/4000K/6000K	3000K/4000K/6000K	3000K/4000K/6000K
CRI	Ra≥90	Ra≥90	Ra≥90	Ra≥90
UGR	<19	<19	<19	<19
Flux	710Lm	1250Lm	710Lm	1250Lm
Size	Ø55*H115mm	Ø65*H135mm	Ø55*H115mm	Ø65*H135mm
IP Rate	IP 20	IP 20	IP 20	IP 20
Chip	OSRAM bridgelux	OSRAM bridgelux	CREE OSRAM	CREE OSRAM

Product size unit (mm)

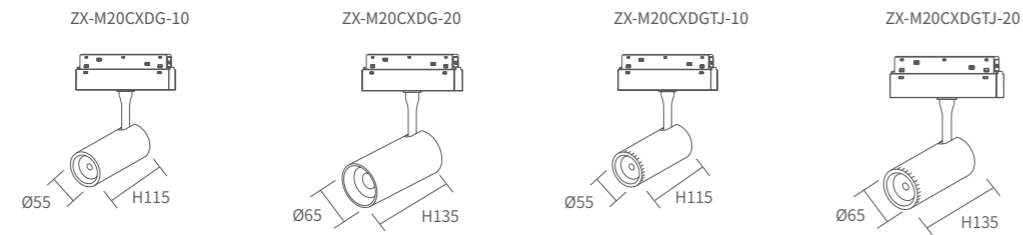

Application : Luxury houses, hotels, clubs, exhibition halls, office buildings, office areas, etc

Products Parameter

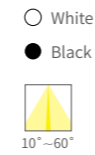

Model No.	ZX-M20CXDX-10 (focusing)	ZX-M20CXDX-10 (fountain)	ZX-M20CXDX-10 (Star)	ZX-M20CXDX-10
Power	10W	7W	7W	10W
Voltage	DC48V	DC48V	DC48V	DC48V
CCT	3000K/4000K/6000K	3000K/4000K/6000K	3000K/4000K/6000K	3000K/4000K/6000K
CRI	Ra≥90	Ra≥90	Ra≥90	Ra≥90
UGR	<19	<19	<19	<19
Flux	710Lm	490Lm	490Lm	710Lm
Size	Ø100*115mm	Ø85*75mm	Ø70*195mm	Ø42 *H300mm, wire length 1m, adjustable height
IP Rate	IP 20	IP 20	IP 20	IP 20
Chip	CREE bridgelux	CREE bridgelux	CREE bridgelux	CREE OSRAM

Product size unit (mm)

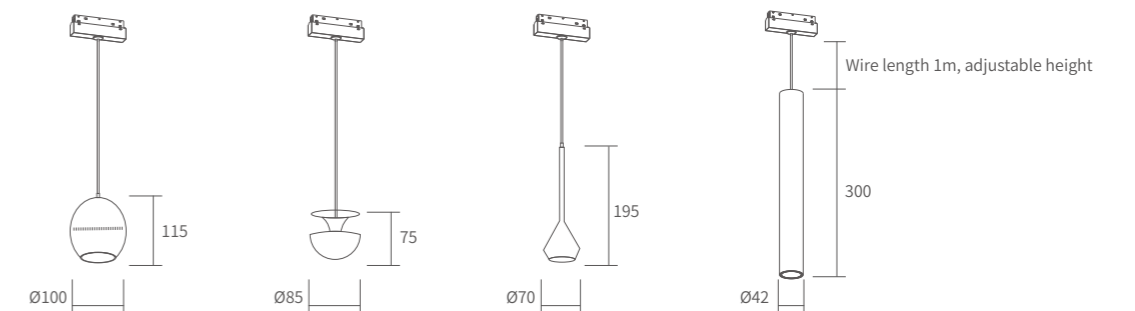

Application : Luxury houses, hotels, clubs, exhibition halls, office buildings, office areas, etc



Smart Dimmable



100% ORIGINAL

The original American Bridgelux 2835 LED chip for light strip.
2835 lamp bead 0.2W support thickness 0.75mm, RA > 90, R9 > 50, luminous efficiency > 128LM/W



Eye protection without stroboscopic

IP20 Protection Level



Minimum cut: 50mm

UGR <19



No blue light hazard •



Customizable



Ra>90

Dimmable, multiple waterproof types available, easy to operate, cut and connect •

LED LIGHT STRIP SERIES

Widely used in various decorative and indirect lighting places

- Interior decoration lighting of amusement park, KTV, cinema, etc
- Decorative lighting of advertisements, signboards and signs
- Bridge, road, garden, holiday decoration lighting
- Outdoor lighting, home ceiling decoration lighting

2835-MONOCHROME SERIES

Features & Applications

Dimmable, multiple waterproof types available, easy to operate, cut and connect

Widely used in various decorative and indirect lighting places

- Interior decoration lighting of amusement park, KTV, cinema, etc
- Decorative lighting of advertisements, signboards and signs
- Bridge, road, garden, holiday decoration lighting
- Outdoor lighting, home ceiling decoration lighting



Application : Luxury houses, hotels, clubs, exhibition halls, office buildings, office areas, etc

CATEGORY

Ra>90 2835 monochrome light strip



ZX-2835G120D (120leds/M)

Power: 12W
Voltage: 24V
Number of LEDs: 120
PCB board width: 8mm
Flux: 1000LM
Minimum cut: 50mm

CCT:

- 2700K
 3000K
 3500K
 4000K
 5000K
 6000K

CATEGORY

Ra>90 2835 monochrome light strip



Power: 10W/18W
Voltage: 24V
Number of LEDs: 120/192
PCB board width: 8mm
Flux: 1080LM/1180LM
Minimum cut: 50mm

CCT:

- 3000K
 3500K
 4000K
 6000K



ZX-2835J120D (120leds/M)

ZX-2835J192D (192leds/M)

Application : Luxury houses, hotels, clubs, exhibition halls, office buildings, office areas, etc



2835-DOUBLE COLOR SERIES

Features & Applications

Dimmable, multiple waterproof types available, easy to operate, cut and connect

Widely used in various decorative and indirect lighting places

- Interior decoration lighting of amusement park, KTV, cinema, etc
- Decorative lighting of advertisements, signboards and signs
- Bridge, road, garden, holiday decoration lighting
- Outdoor lighting, home ceiling decoration lighting

Application : Luxury houses, hotels, clubs, exhibition halls, office buildings, office areas, etc

CATEGORY

Ra>90 2835 two-colour light strip



Power: 12W/18W

Voltage: 24V

Number of LEDs: 120/196

PCB board width: 8mm10mm

Flux: 900LM

Minimum cut: 50mm

CCT:



ZX-2835JS120D (120leds/M)

ZX-2835JS192D (192leds/M)

CATEGORY

Ra>90 2835 two-colour light strip

No voltage drop at 20m

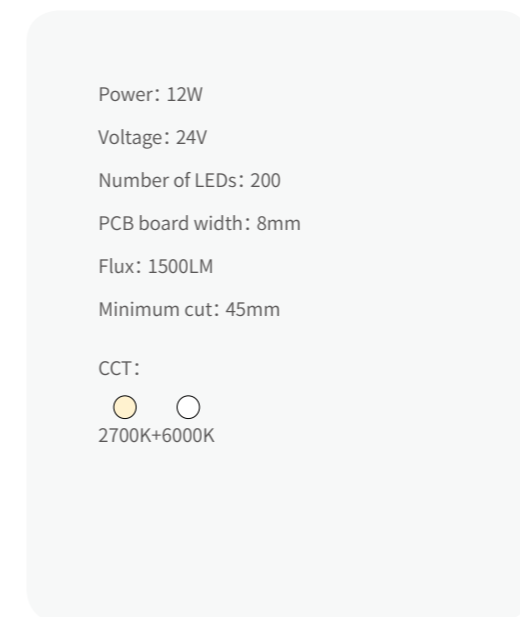

Power: 12W

Voltage: 24V

Number of LEDs: 200

PCB board width: 8mm

Flux: 1500LM

Minimum cut: 45mm

CCT:

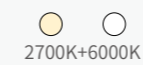

ZX-2835G200D (200leds/M)

Application : Luxury houses, hotels, clubs, exhibition halls, office buildings, office areas, etc



COB SUPER BRIGHT LIGHT STRIP SERIES

FROM NOW ON ELIMINATE LIGHT FLARE AND DARK AREAS

High light transmittance 3D lens

3.5 mm thick PVC transparent soft adhesive, shaped by high-precision processing technology, It forms a fully surrounded 3D curved lens, and the light emitting effect is more uniform and transparent.

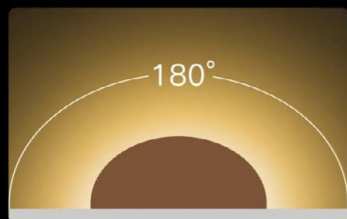

Luminous flux per meter up to 600lm

The lamp bead density is increased, the overall brightness is also greatly improved, and the luminous flux is larger.



Up to 672 beads per meter

There are 10 lamp leds every 1.2cm. The density of lamp leds is 6-8 times that of ordinary lamp strips, and the light output is double bright and delicate.

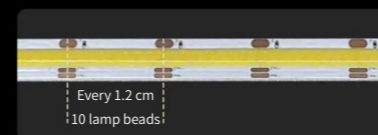

Application : Luxury houses, hotels, clubs, exhibition halls, office buildings, office areas, etc

CATEGORY COB two-colour light strip



ZX-COB608D (608leds/M)

Power: 12W/14W
Voltage: 12V/24V
Number of LEDs: 608
PCB board width: 8mm/10mm
Minimum cut: 26.3mm

CCT:

● ○
2700K+6500K

CATEGORY COB five-in-one RGBCW light strip

Power: 21W
Voltage: 24V
Number of LEDs: 840
PCB board width: 12mm
Minimum cut: 35.7mm

CCT:

● ○ ●
2700K+6500K+ RGB



ZX-COB840D (840leds/M)

Application : Luxury houses, hotels, clubs, exhibition halls, office buildings, office areas, etc



FIVE IN ONE COLORFUL SERIES

CONTROL SHARE & GROUP CONTROL

Share device control with family members
Control a group of devices together

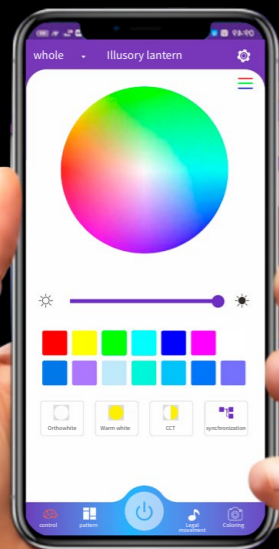

LIGHT MOVES WITH SOUND TO DRIVE THE RHYTHM CREATING A COOL ATMOSPHERE

More than 16 million kinds of colored light of different levels are easily created through mobile App and smart speaker. The dazzling color of game competition, the wonderful music bar, the romantic restaurant and the charming atmosphere of cinema are all moved to your home, and the colorful life starts immediately!

Application : Luxury houses, hotels, clubs, exhibition halls, office buildings, office areas, etc

CATEGORY

Colorful series

Five-in-one RGBCW light strip



Power: 20W/20W

Voltage: 24V

Number of LEDs: 60/96

PCB board width: 12mm

Minimum cut: 100mm/65mm

CCT:



RGB+ C + W

ZX-5050T60D (60leds/M)

ZX-5050T96D (96leds/M)

Application : Luxury houses, hotels, clubs, exhibition halls, office buildings, office areas, etc

LINEAR LIGHT SERIES

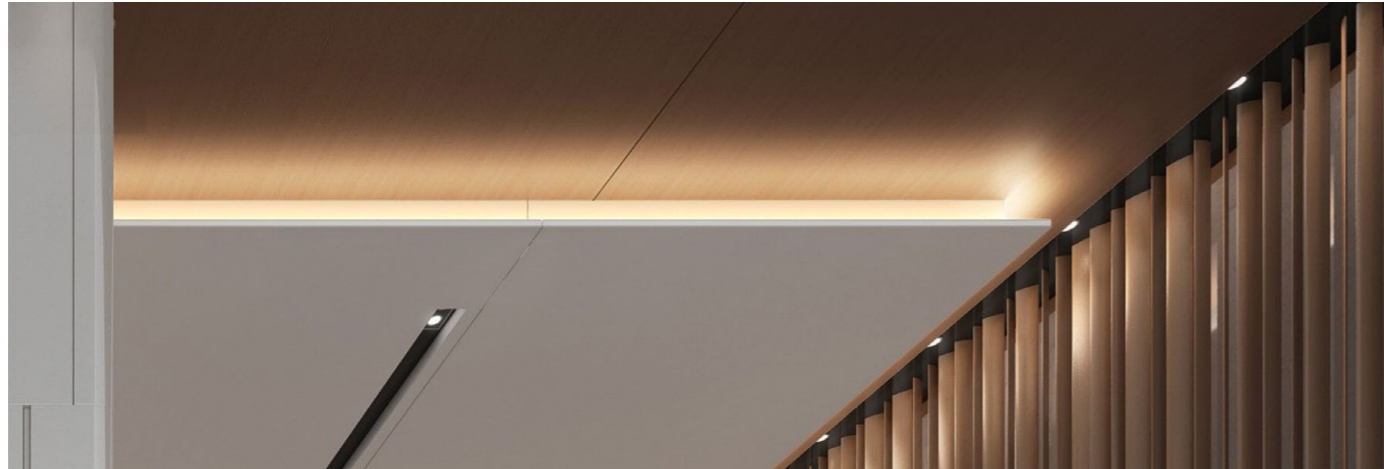

Product features

- High Efficiency
- CE Certification
- UGR <19
- HIGH CRI Ra>90
- Smart Dimmable
- IP44 Protection Level
- Anti-glare cut off angle >30°
- Different sizes
- Eye protection without stroboscopic
- High Quality LED Chip
- Visual comfort
- Customizable

Trimless recessed linear light ZX-101 Material : Aluminum Colour: Aluminum Cover: Milk white Size: W8*9mm	Trimless recessed linear light ZX-108 Material : Aluminum Colour: Aluminum Cover: Milk white Size: W10*10mm	Trimless recessed linear light ZX-509 Material : Aluminum Colour: Aluminum Cover: Milk white Size: W17.4*7mm	Trimless recessed linear light ZX-510 Material : Aluminum Colour: Aluminum Cover: Milk white Size: W13.2*7mm	Trimless recessed linear light ZX-530 Material : Aluminum Colour: Aluminum Cover: Milk white Size: W14.2*8.5mm

Trimless recessed linear light ZX-613 Material : Aluminum Colour: Aluminum Cover: Milk white Size: W17.2*14.2mm	Recessed linear light ZX-530B Material : Aluminum Colour: Aluminum Cover: Milk white Size: W18.4*8.5mm	Recessed linear light ZX-101B Material : Aluminum Colour: Aluminum Cover: Milk white Size: W12*9mm	Recessed linear light ZX-108B Material : Aluminum Colour: Aluminum Cover: Milk white Size: W15.6*10mm	Recessed linear light ZX-508 Material : Aluminum Colour: Aluminum Cover: Milk white Size: W25*7mm

Application : Luxury houses, hotels, clubs, exhibition halls, office buildings, office areas, etc

Recessed linear light ZX-613B Material : Aluminum Colour: Aluminum Cover: Milk white Size: W24*14.2mm	Corner linear light ZX-601 Material : Aluminum Colour: Aluminum Cover: Milk white Size: W15.8*15.8mm	Corner linear light ZX-601A Material : Aluminum Colour: Aluminum Cover: Milk white Size: W15.8*15.8mm	Embedded lace linear light ZX-725 Material : Aluminum Colour: Aluminum Cover: Milk white Size: L48.8*12.5mm	Embedded lace linear light ZX-726 Material : Aluminum Colour: Aluminum Cover: Milk white Size: L48.8*12.5mm

Embedded lace linear light ZX-103B Material : Aluminum Colour: Aluminum Cover: Milk white Size: L35*15mm	Embedded lace linear light ZX-639 Material : Aluminum Colour: Aluminum Cover: Milk white Size: L56*15mm	Embedded lace linear light ZX-646 Material : Aluminum Colour: Aluminum Cover: Milk white Size: L53*24mm	Embedded lace linear light ZX-647 Material : Aluminum Colour: Aluminum Cover: Milk white Size: L48*27mm	Embedded lace linear light ZX-143 Material : Aluminum Colour: Aluminum Cover: Milk white Size: 52.5*13.3mm

Embedded lace linear light ZX-144 Material : Aluminum Colour: Aluminum Cover: Milk white Size: 52.5*13.3mm	Embedded lace linear light ZX-147 Material : Aluminum Colour: Aluminum Cover: Milk white Size: 32.3*13.3mm	Embedded lace linear light ZX-148 Material : Aluminum Colour: Aluminum Cover: Milk white Size: 33*12mm	Embedded lace linear light ZX-195 Material : Aluminum Colour: Aluminum Cover: Milk white Size: L12.7*43mm	Embedded lace linear light/return light slot ZX-187 Material : Aluminum Colour: White Cover: Milk white Size: L76.2*45mm

Embedded lace linear light/return light slot ZX-011 Material : Aluminum Colour: White Cover: Milk white Size: L86*57mm	Ground linear light ZX-632 Material : Aluminum Colour: Black Cover: Milk white Size: L21*26mm	Ground linear light ZX-632A Material : Aluminum Colour: Black Cover: Milk white Size: L28*21mm	Floor linear light ZX-Y009 Material : Aluminum Colour: Aluminum Cover: Milk white Size: L60*13mm

Application : Luxury houses, hotels, clubs, exhibition halls, office buildings, office areas, etc

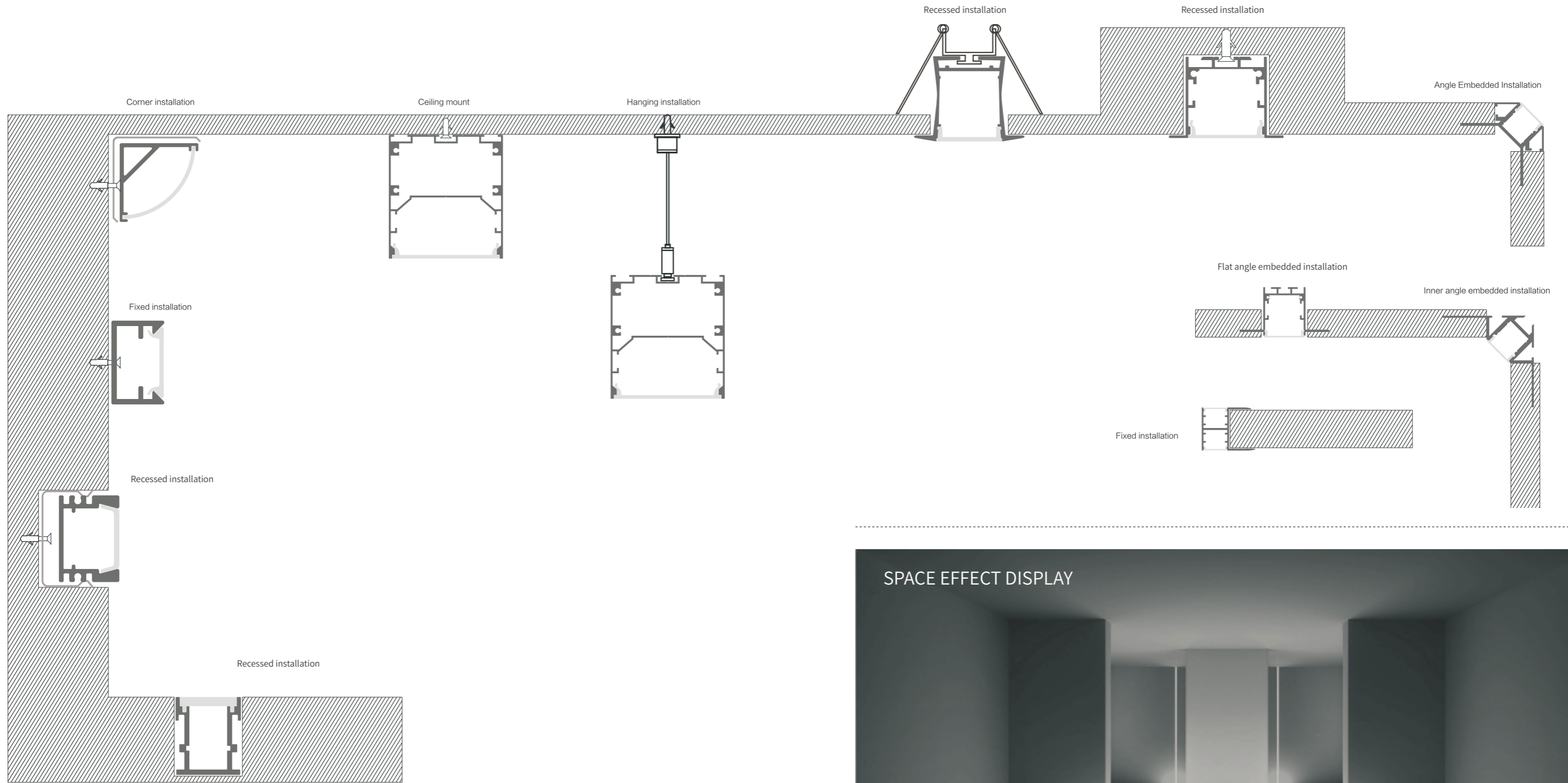

FLOOR LIGHT/ LINEAR LIGHT

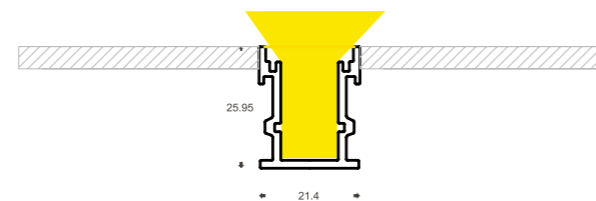

Application : Luxury houses, hotels, clubs, exhibition halls, office buildings, office areas, etc

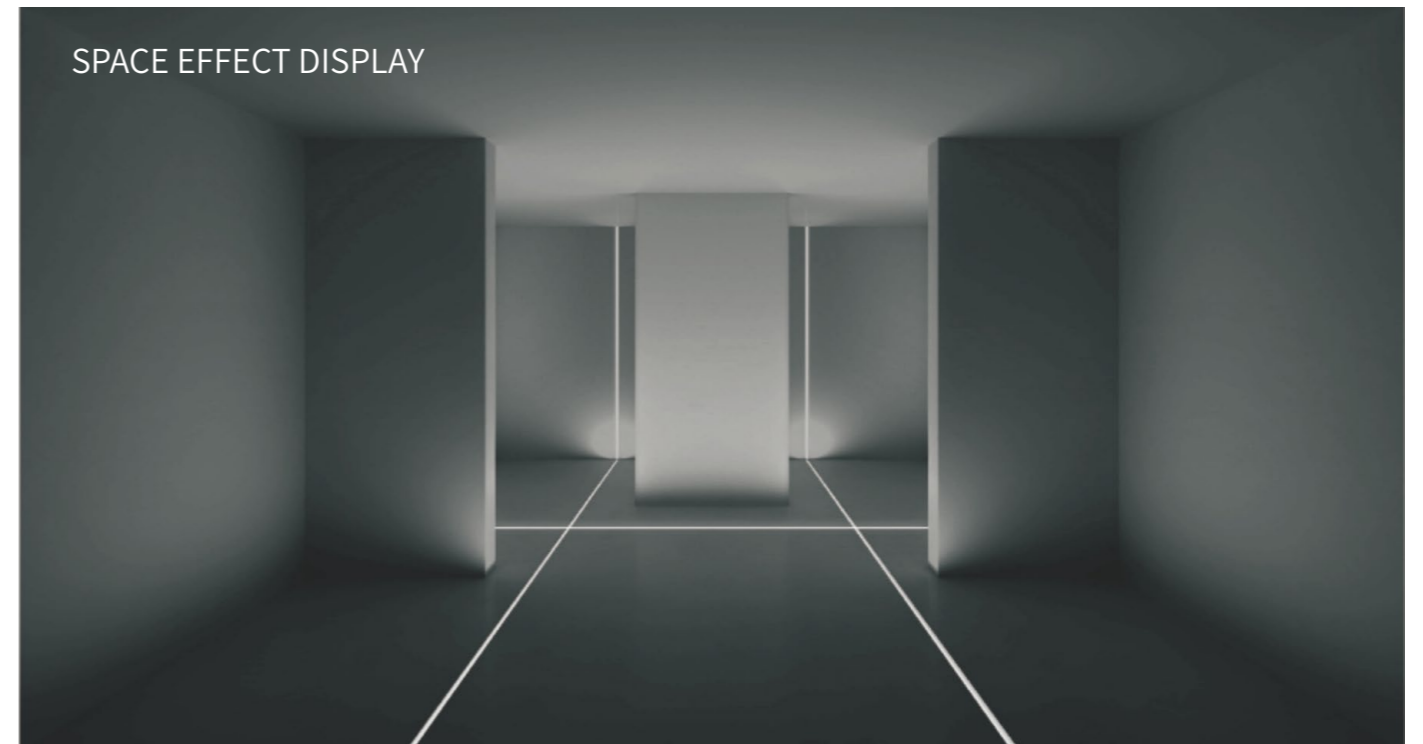

Application : Luxury houses, hotels, clubs, exhibition halls, office buildings, office areas, etc

Smart Home/Lighting - Plan Design



Smart home/lighting - light point bitmap



Smart home/lighting equipment list

ITEM	DESCRIPTION	UNIT	QUANTITY
LED linear light	recessed (double color led strip)	meter	68
LED linear light	embedded (double color led strip)	meter	12
LED light strip driver	Smart led strip controller	piece	14
Power supply	LED strip AC/DC power	piece	12
Smart spotlight	Spotlight+smart LED driver	set	105
Smart downlight	Downlight+smart LED driver	set	13
M20 track light	Magnetic track light+smart LED driver	meter	3
M20 power switch	Magnetic track power switch	piece	13
Composite panel	Smart scene panel	set	24
Composite panel	Smart switch panel	set	3
Engineer gateway	Intelligent wireless gateway	piece	2
Curtain motor	Smart curtain motor	set	10
Smart lock	Smart door lock	piece	1
Air conditioner gateway	Air conditioner gateway	piece	2
Smart sensor	Human motion sensor	piece	5

Key processes of smart lighting solution implementation

DEMAND ANALYSIS	Application scenarios	Home decoration/industrial decoration, indoor/outdoor, public/private area decoration
	Site area	≤150m ² , ≤500m ² , ≤1000m ² , >1000m ²
	Project status	Pre-installation/modification, design/drawing, circuit/network
SCHEME SELECTION	Intelligent communication	Wired/wireless, integrated/transformed, host/distribution
	Functional Configuration	Lighting/gateway, panel/door lock, curtain/security
	Plan details	Layout configuration, scheme list, requirement confirmation
PROGRAM IMPLEMENTATION	Deepen drawings	Intelligent layout, network layout, cabling position
	Installation and debugging	Intelligent equipment, intelligent module, system debugging
	Training delivery	Application training, function acceptance inspection and system delivery
AFTER-SALES SERVICE	Product warranty	1-3 years, non-man-made and natural damage factors
	Inspection visit	Regular return visit, online testing, online Q&A
	Service continuation	Extended warranty renewal, replacement recommendation, service tracking

